

# THE UNITED REPUBLIC OF TANZANIA



## MINISTRY OF WATER



### **Dar es Salaam Water Supply & Sanitation Authority**

DAWASA Building, Dunga/Malaga Street, Mwananyamala Area

P. O. Box 1573, Dar es Salaam. TANZANIA.

Tel. +25522276006/15; Fax: +255222762480; E-mail: dawasaceo@dawasa.co.tz

### **Provision of Consultancy Services for Preparation of Environmental and Social Impact Assessment (ESIA) and Resettlement Action Plan (RAP) Report for Construction of Off-Grid Sanitation Projects**

Ref No: TZ-DAWASA-91652-CS-QCBS

### **Comprehensive Project Brief for the Proposed Simplified Sewerage System to be constructed at Jitegemee Street, Mabibo Ward, Ubungo Municipality**

#### **Submitted to:**

#### **National Environment Management Council**

Regent Estate, Mikocheni, P. O. Box 63154, Dar es Salaam.

**Tel: +255 22 2774852/ 0713608930; Fax: +255 22**

**2774901E-mail: [nemc@nemctz.org](mailto:nemc@nemctz.org)**

#### **Lead Consultant:**

**Prof. Rubhera RAM Mato (PhD), CEng. (T), Reg. EIA Expert**

Mobile: +255754898592; E-Mail: [rubheramato@gmail.com](mailto:rubheramato@gmail.com)

**ROYAL ASSOCIATE  
CONSULTING ENGINEERS**

P.O.BOX 37705-00100, Nairobi

**In Association with**

**G-PES LIMITED**

P.O.BOX 35539

Dar es Salaam

**Submission date: March 3, 2022**

## TABLE OF CONTENTS

<b>THE STUDY TEAM .....</b>	<b>VIII</b>
<b>ABBREVIATIONS .....</b>	<b>IX</b>
<b>EXECUTIVE SUMMARY .....</b>	<b>X</b>
<b>1.0 BACKGROUND AND JUSTIFICATION .....</b>	<b>1</b>
<b>1.1 NATURE OF THE PROJECT .....</b>	<b>3</b>
<b>2.0 PROJECT DESCRIPTION .....</b>	<b>3</b>
2.1 PROJECT LOCATION .....	3
2.2 ACCESSIBILITY .....	6
2.3 SPECIFIC FEATURES .....	7
2.4 LAND USE AND LAND OWNERSHIP .....	7
<b>2.5 PROJECT ACTIVITIES .....</b>	<b>7</b>
2.5.1 MOBILIZATION OR PRE-CONSTRUCTION PHASE .....	7
2.5.2 CONSTRUCTION PHASE .....	7
2.5.3 DEMOBILIZATION PHASE .....	8
2.5.4 OPERATION PHASE .....	8
2.5.5 DECOMMISSIONING PHASE .....	8
<b>2.6 PROJECT DESIGN .....</b>	<b>9</b>
2.6.1 DESIGN CRITERIA .....	9
2.6.1.1 <i>Design Criteria Development</i> .....	9
2.6.1.2 <i>Design Horizon</i> .....	9
2.6.1.3 <i>Pipe materials</i> .....	10
2.6.1.4 <i>Minimum depth of sewer</i> .....	10
2.6.1.5 <i>Sewer ventilation</i> .....	10
2.6.1.6 <i>Inspection chambers</i> .....	11
2.6.1.7 <i>Maximum number of houses to be connected to a single sewer line</i> .....	11
2.6.1.8 <i>Minimum sewer gradient</i> .....	11
2.6.1.9 <i>Minimum sewer diameter</i> .....	12
2.6.2. TECHNOLOGY DESCRIPTION .....	12
2.6.2.2 <i>Hydraulics</i> .....	12
2.6.3. SERVICE CONNECTION .....	13
2.6.4 DEPTH OF SEWERS .....	13
2.6.5 MANHOLES AND OTHER APPURTENANCES .....	14

2.6.6 CONSTRUCTION MATERIAL .....	14
2.6.7 TYPICAL SSS HOUSE CONNECTION LAYOUT .....	15
3.0 POLICIES, LEGISLATION AND INSTITUTIONAL ASPECT .....	17
3.1 RELEVANT POLICIES .....	17
3.1.1 National Environment Policy 1997 .....	17
3.1.2 National Land Policy of 1997 .....	18
3.1.3 Construction Industry Policy (2003) .....	18
3.1.4 National Health Policy (2003) .....	18
3.1.5 National Gender Policy of 2000 .....	19
3.1.6 National Human Settlements Development Policy (2000) .....	19
3.2 PRINCIPAL LEGISLATIONS AND REGULATIONS .....	20
3.2.1 Environmental Management Act (2004) .....	20
3.2.2 The Environmental Management (Fees and Charges) Regulations, 2021 .....	21
3.2.3 The Environmental Management (Control of hazardous Waste) regulations, 2021 ...	21
3.2.4 The Environmental Management (Control of Noise and vibration) regulations, 2015.	22
3.2.5 The Environmental Management (Prohibition of Plastic Carrier bags) regulations, 2019	22
3.2.6 The Environmental Management (Solid Waste Management) regulations, 2007 .....	23
3.2.7 The Environmental Management (Water Quality) regulations, 2009 .....	23
3.2.8 The Environmental Management (Air Quality) regulations, 2009 .....	24
3.2.9 The Environmental Management (Soil Quality) regulations, 2009 .....	24
3.2.10 Occupational Health and Safety Act 2003 .....	25
3.2.11 The Water Supply and Sanitation Act No. 12 of 2009 .....	25
3.2.12 Engineers Registration Act and its Amendments 1997 and 2007 .....	25
3.2.13 The Contractors Registration (Amendment) Act, 2008 .....	26
3.2.14 The Architects and Quantity Surveyors Act (1997) .....	26
3.2.15 The Urban Planning Act (2007) .....	26
3.2.16 Public Health Act (2009) .....	27
<b>4.0 BASELINE INFORMATION .....</b>	<b>28</b>
4.1 INTRODUCTION .....	28
4.2 METHODOLOGY OF CONDUCTING BASELINE STUDY .....	28
4.3 CRITERIA FOR BASELINE ENVIRONMENT STUDY .....	30
4.4 PHYSICAL ENVIRONMENT .....	30
4.4.1 Soil .....	30
4.4.2 Topography .....	30
4.5 METEOROLOGICAL CONDITIONS .....	30

4.5.1 Wind.....	31
4.5.2 Rainfall.....	31
4.5.4 Temperature.....	31
4.6 HYDROLOGY.....	32
4.6.2 Ground water characteristics.....	32
4.7 BASELINE PARAMETERS MEASUREMENTS.....	32
4.7.1 Ambient Air Quality.....	32
4.7.2 <i>Noise and Vibration</i> .....	33
4.8 SOCIAL ECONOMIC ENVIRONMENT.....	33
4.8.1 Population and Demographic Patterns.....	33
4.8.2 Ethnic composition.....	33
4.8.3 Occupation and Income.....	33
4.8.4 Education.....	34
4.8.5 Health service.....	35
4.8.5 Water and Sanitation.....	36
4.8.6 Energy.....	37
4.8.6 Housing.....	38
<b>5.0 STAKEHOLDER VIEWS ON THE PROPOSED PROJECT.....</b>	<b>39</b>
<b>6.0 PROJECT REQUIREMENTS AND WASTE GENERATION.....</b>	<b>40</b>
6.1 PROJECT REQUIREMENTS.....	40
6.1.1 <i>Construction materials and labour force</i> .....	40
6.1.2 <i>Labour force</i> .....	40
6.1.3 <i>Machinery and Equipment</i> .....	40
6.2 WASTES GENERATION.....	40
6.2.1 <i>Liquid waste management</i> .....	41
6.2.2 <i>Solid waste management</i> .....	41
<b>7.0 POTENTIAL IMPACTS.....</b>	<b>42</b>
7.1 MOBILIZATION PHASE.....	42
7.1.1 POSITIVE IMPACTS.....	42
7.1.1.1 <i>Employment opportunities</i> .....	42
7.1.2 NEGATIVE IMPACTS.....	42
7.1.2.1 <i>Noise pollution</i> .....	42
7.1.2.2 <i>Air Pollution from dust emission</i> .....	43
7.2 CONSTRUCTION PHASE.....	43
7.2.1 POSITIVE IMPACTS.....	43

7.2.1.1	<i>Employment opportunities</i> .....	43
7.2.1.2	<i>Increased socio-cultural interaction</i> .....	43
7.2.1.3	<i>Increased Revenue to the nation through taxes, both direct and indirect</i> .....	44
7.2.1.4	<i>Cost reduction for sewage management</i> .....	44
7.2	<b>2 NEGATIVE IMPACTS</b> .....	44
7.2.2.1	<i>Increased HIV/AIDS and other sexual related diseases:</i> .....	44
7.2.2.2	<i>Land degradation and increased erosion</i> .....	45
7.2.2.3	<i>Noise pollution</i> .....	45
7.2.2.4	<i>Air Pollution from dust emission</i> .....	46
7.2.2.5	<i>High Risk of Health associated with construction work</i> .....	46
7.2.2.6	<i>Waste generation during construction</i> .....	47
7.2.2.7	<i>Sewer leakage/overflow</i> .....	47
7.3	<b>OPERATION PHASE</b> .....	48
7.3.1	<b>POSITIVE IMPACTS</b> .....	48
7.3.1.1	<i>Improved social-economic livelihood and dignity within the beneficiary society</i> .....	48
7.3.1.2	<i>Increased Revenue to the nation through taxes, both direct and indirect</i> .....	48
7.3.1.3	<i>Cost reduction for sewage management</i> .....	48
	CONSTRUCTION OF SIMPLIFIED SEWERAGE SYSTEM WILL REDUCE THE CONTAMINATION/POLLUTION OF SOIL AND GROUNDWATER BECAUSE THE WASTE WATER FROM TOILETS WILL DIRECTLY FLOW TO THE PONDS. THE SYSTEM WILL ALSO REDUCE THE DESLUDGING INTO THE OPEN STORM WATER CHANNELS ESPECIALLY DURING RAINY SEASON. ....	48
7.3.2	<b>NEGATIVE IMPACTS</b> .....	49
7.3.2.1	<i>Sewer leakage/overflow</i> .....	49
<b>8.0</b>	<b>ACTION PLAN FOR PREVENTION AND MANAGEMENT OF ACCIDENTS DURING IMPLEMENTATION STAGE</b> .....	<b>49</b>
8.1	<b>OCCUPATIONAL HEALTH AND SAFETY</b> .....	49
8.1.1	<b>EMERGENCY PREPAREDNESS PLAN</b> .....	50
8.2	<b>SECURITY</b> .....	50
8.3	<b>MONITORING, MAINTENANCE AND REPAIR</b> .....	50
<b>9.0</b>	<b>ENVIRONMENTAL AND SOCIAL MANAGEMENT PLAN</b> .....	<b>50</b>
9.1	<b>ENVIRONMENTAL AND SOCIAL MANAGEMENT PLAN</b> .....	50
<b>10.0</b>	<b>MONITORING PLAN</b> .....	<b>58</b>
10.1	<b>ENVIRONMENTAL MONITORING</b> .....	58
<b>11.0</b>	<b>DECOMMISSIONING PLAN</b> .....	<b>63</b>

<b>11.1 DECOMMISSIONING .....</b>	<b>63</b>
11.2 AIM OF THE PRELIMINARY PLAN.....	63
11.3 CONTENT OF THE PRELIMINARY PLAN.....	64
11.4 PROJECT DECOMMISSIONING METHODOLOGY AND SCHEDULE.....	64
<b>POST-REMOVAL ACTIVITIES: POST-PROJECT REMOVAL MONITORING WILL CONTINUE FOR ONE YEAR .....</b>	<b>66</b>
<b>12.0 PROJECT BUDGET .....</b>	<b>66</b>
<b>APPENDIX I: LIST OF STAKEHOLDERS CONSULTED.....</b>	<b>67</b>
<b>APPENDIX II: PERMIT TO USE THE WALKWAYS/ALLEYS FOR SSS INFRASTRUCTURES</b>	<b>69</b>
<b>APPENDIX III. MINUTES OF MEETINGS CONDUCTED .....</b>	<b>70</b>
<b>APPENDIX IV. ARCHITECTURAL DRAWINGS.....</b>	<b>74</b>
<b>ANNEX I: GENERIC ENVIRONMENTAL MANAGEMENT FOR CONSTRUCTION ACTIVITIES .....</b>	<b>79</b>





## LIST OF FIGURES

Figure 1: A Map of Dar es salaam region showing the project Municipal.....	5
Figure 2: An Extract Google view to show the Location of the project area .....	6
Figure 3: House connection detail.....	13
Figure 4: Standard Manhole detail .....	14
Figure 5: Simplified Sewerage system layout Mabibo Jitegemee .....	16
Figure 6: Stakeholder’s consultation meeting at Ubungo Municipal office and Mabibo jitegemee community .....	39

## LIST OF TABLES

Table 1: Minimum depth of sewer .....	10
Table 2: Various environmental attributes.....	29
Table 3: Distribution of public secondary schools in Ubungo Municipal.....	34
Table 4: Distribution of health facilities in Ubungo Municipal .....	35
Table 5: Waste Generation and collection in Ubungo Municipality .....	37
Table 6: Stakeholders issues and concerns .....	39
Table 7: Management of construction and operation wastes .....	41
Table 8: Environmental and Social Management Plan for the Proposed Construction of Simplified sewerage system at Mabibo jitegemee area, Ubungo Municipal.....	53
Table 9: Monitoring Plan for the Proposed Construction of Simplified sewerage system at Mabibo Jitegemee Mabibo Ward Ubungo Municipality .....	59

THE STUDY TEAM

NAME	POSITION	NEMC Reg. No.	SIGNATURE
Prof. Rubhera RAM Mato	Environmental and ESIA Team Leader	Registered NEMC/EIA/0092	
Mr. Robert Kishiki	Sociologist	Not Registered	
Mr. Emmanuel Rajab	Environmental Engineer	Not Registered	
Mr. Melkizedeck Stephano	Environmentalist	Not Registered	

## ABBREVIATIONS

AAQ	Ambient Air Quality
AIDS	Acquired Immuno-Deficiency Syndrome
DAWASA	Dar es Salaam Water and Sanitation Authority
EIA	Environmental Impact Assessment
EMP	Environmental Management Plan
ESIA	Environmental and Social Impact Assessment
ESMP	Environmental and Social Monitoring Plan
GoT	Government of Tanzania
HIV	Human Infection Virus
IDA	International Development Association
LGA	Local Government Authority
NEMC	National Environment Management Council
NEP	National Environment Policy
OGSP	Off-Grid Sanitation Project
PPE	Personal Protective Equipment
PVC	Polyvinyl Chloride
RAP	Resettlement Action Plan
SSS	Simplified Sewerage System
STDS	Sexual Transmitted Diseases
TANESCO	Tanzania National Electric Supply Company
WSP	Wastewater Stabilization Ponds

## EXECUTIVE SUMMARY

### Comprehensive Project Brief for the Proposed Simplified Sewerage System to be constructed at Jitegemee Street, Mabibo Ward, Ubungo Municipality

**Proponent:** DAWASA

**Proponent's Contact:** DAWASA House, Dunga/Malanga  
Street/Mwananyamala  
P.O Box 1573 DSM  
Tel: +255222760006/15  
Fax: +255222762480  
Email Address: [info@dawasa.go.tz](mailto:info@dawasa.go.tz)

**EIA Expert:** Prof. Rubhera RAM Mato  
(PhD), CEng. (T), Reg. EIA Expert  
Mobile: +255754898592  
E-Mail: [rubheramato@gmail.com](mailto:rubheramato@gmail.com)

## INTRODUCTION

The Government of the United Republic of Tanzania (GoT) through the Dar es Salaam Water and Sewerage Authority (DAWASA) under the Ministry of Water intends to implement an Off-Grid Sanitation Project (OGSP) in Dar es Salaam City to serve peri-urban areas not connected to the central sewerage system. DAWASA has received financing from the International Development Association (IDA) in the form of a credit to implement the project. Before implementing the project, the law in Tanzania requires an Environmental Impact Assessment to be conducted and approved by the relevant authority. To comply with the law in Tanzania, the DAWASA intends to apply a portion of the proceeds of the credit to eligible payments for consulting services for Preparation of Environmental and Social Impact Assessment (ESIA) and Resettlement Action Plan (RAP) Report for the

construction of off-grid sanitation projects.

Dar es Salaam is the largest and most important commercial and industrial center in Tanzania. The city has an estimated population of about 5.0 million and is projected to double at the end of the project horizon of 25 years. About 10% of the population is served by sewers and the rest almost depend on on-site sanitation systems. The sewer coverage is only limited to the area within the city center with a total length of 67.8km and the system is based on a separate system and discharges their effluent into oxidation ponds, and into the sea through a sea outfall of about 1.03km long. The onsite sanitation systems result in Faecal sludge of which handling and management throughout the sanitation chain (from domestic containment, transportation as well as disposal and treatment) is currently hygienically inadequate thus posing environmental and public health risks. The Off-Grid project is intended to address these challenges. The Off-Grid project is divided into several subprojects which will be implemented in the five municipalities of Dar es Salaam City. One of these is the Construction of Simplified Sewerage System at Mabibo Jitegemee, in Mabibo Ward, Ubungo Municipality. The project is planned to connect 250 households with an estimated population of 1,365 people. According to the United Republic of Tanzania Ministry of water, Design manual for water supply and wastewater disposal domestic requirements (2009) 120l/c/day has been adopted in the designing. 80% conversion to wastewater of the consumption in the design has been considered. Therefore, the estimate amount of sewage/Wastewater to be generated per day from the given population is 1,536.576m<sup>3</sup>/day as per design manual.

This study was conducted following the Environmental Management (Environmental Impact Assessment and Audit) (Amendment) Regulations, 2018 along with the Environmental Impact Assessment and Audit Regulations of 2005. These Regulations provide legal procedures for implementing the requirements of the Environmental Management Act Cap.191 of 2004. The Regulations give a

mandate to NEMC to oversee the EIA process, which culminates with an award of the EIA Certificate by the Ministry responsible for Environment.

Following the EIA Regulations, NEMC is mandated to screen projects and make decisions of the level of EIA required as well as evaluating the adequacy of respective environmental statements. Considering the nature and size of the proposed “Simplified Sewerage System in Ubungo Municipality”, the project falls under Category “B2” (Non-Mandatory) following Reg.4 (1)(c) and First Schedule of the amended 2018 Regulations which categorizes the *night soil collection and treatment* being under the ‘*List of small-scale activities and enterprises that require registration but shall not require Environmental Impact Assessment. Further, the projects shall not require screening and scoping, rather, the Project Brief shall be examined and issued with an Environmental Impact Assessment Certificate*’. The regulations require developers to prepare and submit to the National Management Council (NEMC) filled EIA registration forms and “Project Briefs” for all B2 projects. The preparation and content of the “Project Briefs” are provided under Reg.6 (1). The same has been followed in preparing this “Project Brief”. The study for preparing this project brief was conducted from July to October 2020.

This project brief for the Proposed Construction of Simplified Sewerage System in Ubungo Municipality is being submitted to NEMC together with EIA Registration Forms for EIA Certificate decision.

### PROJECT DESCRIPTION

The project area is accessible via Morogoro road then Mpiji Street and Kigogo road 9.8 Kilometers from the City Center. The project area is unplanned settlement with restricted access roads for fecal sludge emptying trucks. Currently, this area is being served through on-site sanitation management that involves domestic containment and emptying trucks that are not satisfactorily managed.

The proposed project intends to use the existing alleys (*vichocho*) for installing the simplified sewer pipelines. The local government in the project area has agreed with DAWASA through a formal meeting held on 08/07/2021 to use the alleys whether formal or non-formal for the construction of a simplified sewerage system and the associated appurtenances to improve the sanitation conditions

### POLICIES, LEGISLATION AND INSTITUTIONAL ASPECT

Sector policies that were reviewed when executing the proposed development are;

- National Environment Policy 1997
- National Land Policy of 1997
- Construction Industry Policy (2003)
- National Health Policy (2003)
- National Gender Policy of 2000
- National Human Settlements Development Policy (2000)

Principal Acts, regulations and guidances that support and provide guidelines to implement the intended project are;

- Environmental Management Act (2004)
- The Environmental Management (Fees and Charges) Regulations, 2021
- The Environmental Management (Control of hazardous Waste) regulations, 2021
- The Environmental Management (Control of Noise and vibration) regulations, 2015
- The Environmental Management (Prohibition of Plastic Carrier bags) regulations, 2019
- The Environmental Management (Solid Waste Management) regulations, 2007
- The Environmental Management (Water Quality) regulations, 2009
- The Environmental Management (Air Quality) regulations, 2009

- The Environmental Management (Soil Quality) regulations, 2009
- Occupational Health and Safety Act 2003
- The Water Supply and Sanitation Act No. 12 of 2009
- Engineers Registration Act and its Amendments 1997 and 2007
- The Contractors Registration (Amendment) Act, 2008
- The Architects and Quantity Surveyors Act (1997)
- The Urb World Bank guidelines for Environmental Management and Planning Act (2007)
- Public Health Act (2009)

### **STAKEHOLDERS ISSUES AND CONCERNS**

Different stakeholders were consulted. Among of the issues that arise during consultation at the Ubungo Municipal Council and community at Mabibo are:

#### **Facilities to be developed**

- Proposed on-site incinerator for public toilet for pads safe disposal and privacy to women.
- Public toilets should incorporate Change room and Shaving room
- The proposed facilities should be well protected

#### **Awareness to the community**

- Awareness to the people on the system operation, since it is a new technology
- Awareness to the community to avoid riots in the future
- Educate the community to avoid the use of detrimental disinfectants to the system so as to avoid system failure and contaminated manures.

### **PROJECT REQUIREMENTS AND WASTE GENERATION**

#### **Project requirements**

The main materials for construction of Simplified sewerage system include cement, aggregates (stones), water, steel, sand, timbers, blocks, PVC pipes, and gravels. During the construction phase the project will require not less than 100 workers both skilled and non-skilled laborers for each phase of project construction. During operational phase it is estimated that 30 unskilled workers will be retained for operating the system.

Equipment expected to be used during the construction works are Tippers, Concrete Mixers, poker vibrators, Wheel barrow, Compactor, etc.

### **Wastes generation**

The major wastes generation associated with the project are solid wastes and liquid waste. During the maximum operation phase a total of 100m<sup>3</sup> per day of liquid waste is estimated to be received at the downstream receiving chamber of the Fecal sludge treatment facility close to the project site. During construction it is expected that at least 60kg of solid wastes will be produced.

### POTENTIAL IMPACTS

The following impacts were identified to be likely to occur during mobilization phase:

- Employment opportunities
- Noise pollution
- Air pollution from dust emission
- Blockage of paths

The following impacts were identified to be likely to occur during the construction phase;

- Employment opportunities
- Increased socio-cultural interaction
- Increased Revenue to the nation through taxes, both direct and indirect
- Cost reduction for sewage management

- Increased HIV/AIDS and other sexual related diseases
- Land degradation and increased erosion
- Noise pollution
- Air Pollution from dust emission
- High Risk of Health associated with construction work
- Waste generation during construction
- Sewer leakage/overflow
- Blockage of paths

The following impacts were identified to be likely to occur during the operational phase;

- Improved social-economic livelihood and dignity within the beneficiary society
- Increased Revenue to the nation through taxes, both direct and indirect
- Cost reduction for sewage management
- Sewer leakage/overflow

#### MITIGATION MEASURES AND ENVIRONMENTAL AND SOCIAL MANAGEMENT PLAN (ESMP)

The options to minimize or prevent the identified adverse social and environmental impacts as well as a monitoring plan have been suggested in this report and are contained in the ESMP. Many of them are based on good engineering practices and the timely responsiveness of the responsible institution. The ESMP describes the implementation schedule of the proposed mitigation measures as well as planning for long-term monitoring activities. It defines the roles and responsibilities of different actors of the plan. The Approach environmental and social costs amount to Tshs 38,000,000.00. The estimated annual costs for carrying out the proposed environmental and social motoring program amounts to TSH 7,500,000.00.

#### DECOMMISSIONING PLAN

The decommissioning is not anticipated in the foreseeable future. However, if this will happen, may entail change of use (functional changes) or demolition triggered by change of land use. In view of this, specific mitigation measures pertaining to environmental impacts of decommissioning works cannot be proposed at the moment with a reasonable degree of certainty.

### PROJECT BUDGET

The investment cost for the proposed Simplified sewerage system is estimated to be around Tshs. 1.0 billion that will be financed The World Bank.

## Comprehensive Project Brief for the Proposed Simplified Sewerage System to be constructed at Jitegemee Street, Mabibo Ward, Ubungo Municipality

### 1.0 BACKGROUND AND JUSTIFICATION

The Government of the United Republic of Tanzania (GoT) through the Dar es Salaam Water and Sewerage Authority (DAWASA) under the Ministry of Water intends to implement an Off Grid Sanitation Project (OGSP) in Dar es Salaam City to serve peri-urban areas not connected to the central sewerage system. DAWASA has received financing from the International Development Association (IDA) in the form of a credit to implement the project. Prior to implementing the project, the law in Tanzania requires an Environmental Impact Assessment to be conducted and approved by relevant authority. In order to comply with the law in Tanzania, the DAWASA intends to apply a portion of the proceeds of the credit to eligible payments for consulting services for Preparation of Environmental and Social Impact Assessment (ESIA) and Resettlement Action Plan (RAP) Report for construction of off grid sanitation projects.

Dar es Salaam is the largest and most important commercial and industrial center in Tanzania. The city has an estimated population of about 5.0 million and is projected to double at the end of the project horizon of 25 years. About 10% of the population is served by sewers and the rest almost depend on on-site sanitation systems. The sewer coverage is only limited to the area within city centre with a total length of 67.8km and the system is based on a separate systems and discharge their effluent into oxidation ponds, and into the sea through sea outfall of about 1.03km long. The onsite sanitation systems result into Faecal sludge of which handling and management throughout the sanitation chain (from domestic containment, transportation as well as disposal and treatment) is currently hygienically inadequate thus posing environmental and public health risks. The Off Grid project is intended to address these challenges. The Off Grid project is divided into several subprojects which will be implemented in the five municipalities of Dar es Salaam City. One of these

---

is the Construction of Simplified Sewerage System at Mabibo jitegeme area, Ubungo Municipality. The project is planned to connect 250 households with an estimated population of 18,247 people. According to the United Republic of Tanzania Ministry of water, Design manual for water supply and wastewater disposal domestic requirements (2009) 120l/c/day has been adopted in the designing. 80% conversion to wastewater of the consumption in the design has been considered. Therefore, the estimate amount of sewage/Wastewater to be generated per day from the given population is 1,751.712m<sup>3</sup>/day as per design manual.

This study was conducted in accordance with the Environmental Management (Environmental Impact Assessment and Audit) (Amendment) Regulations, 2018 along with the Environmental Impact Assessment and Audit Regulations of 2005. These Regulations provide legal procedures for implementing the requirements of the Environmental Management Act Cap.191 of 2004. The Regulations give mandate to NEMC to oversee the EIA process, which culminates with an award of the EIA Certificate by the Ministry responsible for Environment.

In accordance with the EIA Regulations, NEMC is mandated to screen projects and make decisions of level of EIA required as well as evaluating the adequacy of respective environmental statements. Considering the nature and size of the proposed "Simplified Sewerage System in Ubungo Municipality", the project falls under Category "B2" (Non-Mandatory) in accordance with Reg.4 (1)(c) and First Schedule of the amended 2018 Regulations which categorizes the *night soil collection and treatment* being under the '*List of small-scale activities and enterprises that require registration but shall not require Environmental Impact Assessment. Further, the projects shall not require screening and scoping, rather, the Project Brief shall be examined and issued with an Environmental Impact Assessment Certificate*'. The regulations require developers to prepare and submit to the National Management Council (NEMC) filled EIA registration forms and "Project Briefs" for all B2 projects. The preparation and content of

---

the “Project Briefs” is provided under Reg.6 (1). The same has been followed in preparing this “Project Brief”. The study for preparing this project brief was conducted from July to October 2020.

This project brief for the Proposed Construction of Simplified Sewerage System in Ubungo Municipality is being submitted to NEMC together with EIA Registration Forms for EIA Certificate decision.

## **1.1 NATURE OF THE PROJECT**

A simplified Sewerage System is a sewerage network that is constructed using smaller diameter pipes laid at a shallower depth and at a flatter gradient, this type of sewerage system allows for a more flexible design at lower cost. The pipes are usually laid within the property boundaries, through either the back or front yards, access ways which are too narrow for heavy traffic, therefore little excavation is required. The proposed project concerns construction of Simplified sewerage system for public use at Jitegemee Street, Mabibo Ward, Ubungo Municipality, the network will cover distance of about 964m. The nature of the project enhances environmental protection through proper handling and disposal of domestic sewage. According to First Schedule of the EIA and Audit Regulations (Amended) of 2018, the nature of the project is small and entails no significant impacts. The project can be categorised as Type B2, which according to the regulations are “small-scale activities and enterprises that require registration but shall not require Environmental Impact Assessment. Further, the projects shall not require screening and scoping, rather, the Project Brief shall be examined and issued with an Environmental Impact Assessment Certificate”.

## **2.0 PROJECT DESCRIPTION**

### **2.1 Project Location**

Mabibo is an administrative ward situated at -6.808642 Longitude, 39.22341 Latitude in Ubungo Municipal of Dar-es-salaam Region. Most of streets within Mabibo are unplanned settlement with restricted access roads for faecal sludge

---

emptying trucks. Furthermore, the ward is characterized by having underlying geographical formation setback where water table is significantly high and this hinders proper faecal sludge management.

Currently, this area is being served through on site sanitation management that involve domestic containment and emptying trucks that are not satisfactory managed. Apart from illegal emptying, underground seepage of faecal sludge may also contaminate ground water leading to water related diseases within this area. To address above challenges, we recommend construction of simplified sewerage system as the solution of faecal sludge management within the area. The project will be implemented at Mabibo jitegemee street, figure 1 and 2.

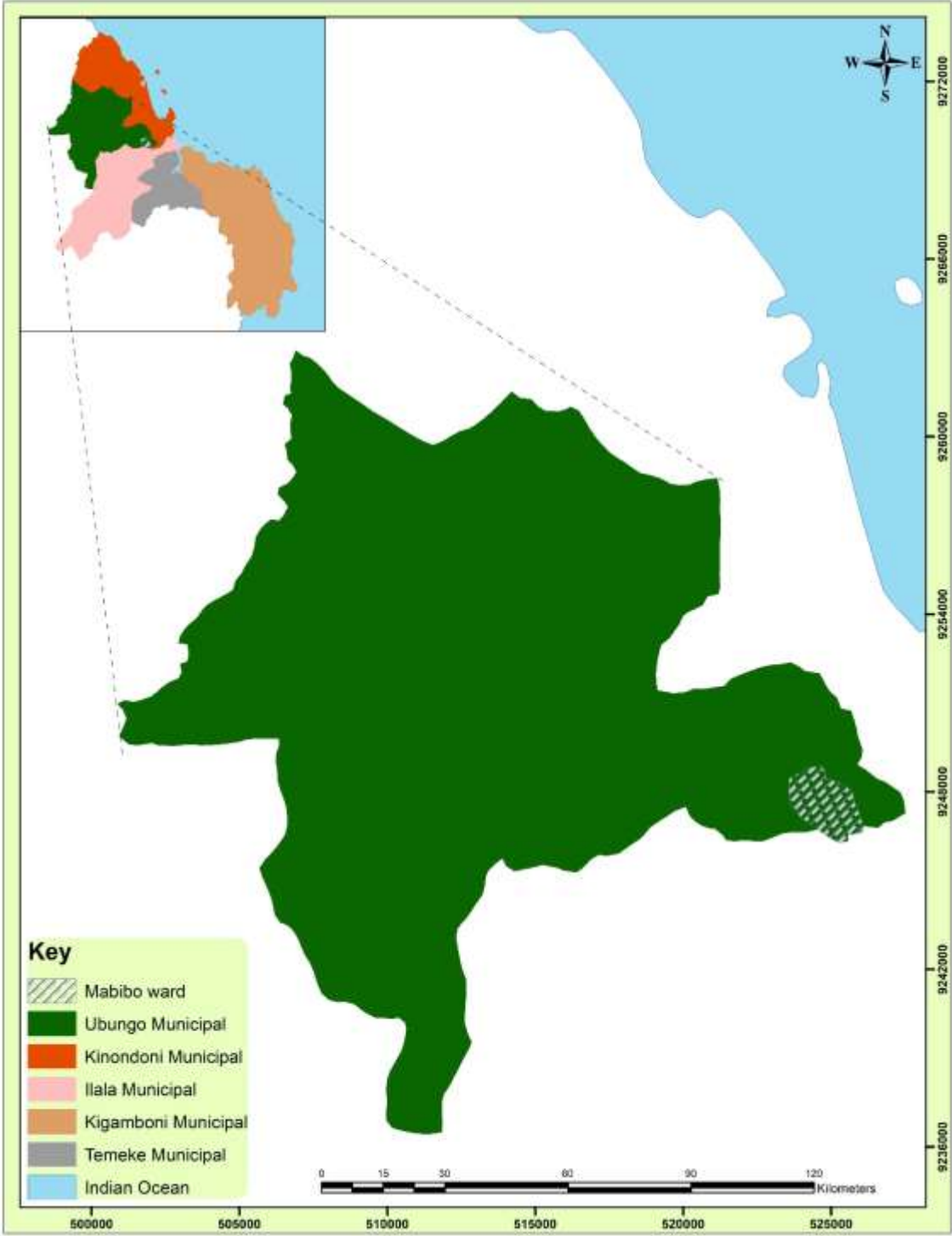

Figure 1: A Map of Dar es salaam region showing the project Municipal

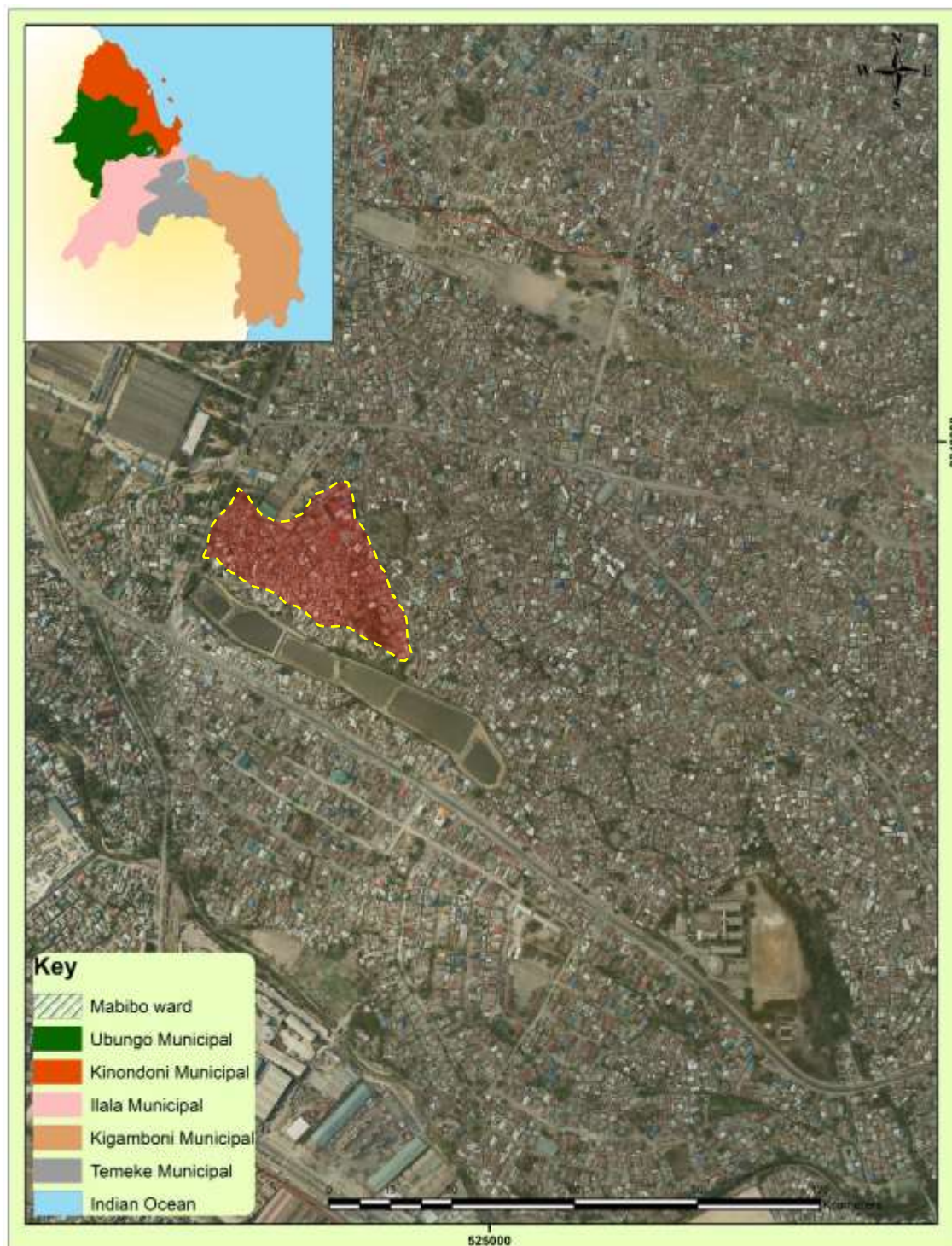

Figure 2: An Extract Google view to show the Location of the project area

## 2.2 Accessibility

The project area is accessible via Morogoro road then Mpiji Street and Kigogo road 9.8 Kilometers from the City Center. The project area is unplanned settlement with restricted access roads for feacal sludge emptying trucks.

### **2.3 Specific Features**

The project area is being served through on site sanitation management that involve domestic containment and emptying trucks that are not satisfactory managed. Apart from illegal emptying, underground seepage of faecal sludge may also contaminate ground water leading to water related diseases within this area

### **2.4 Land Use and Land Ownership**

The project site is surrounded by residential buildings and is close to and Wastewater stabilization ponds at the downstream. The proposed project intends to use the existing alleys (*vichocho*) for installing the simplified sewer pipelines. The local government in the project area has entered into agreement with DAWASA through a formal meeting held on 05/07/2021 to use the alleys whether formal or non-formal for construction of simplified sewerage system and the associated appurtenances so as to improve the sanitation conditions, appendix II.

After installation of sewer pipes the narrow walkways which are prone to erosion will be paved.

## **2.5 PROJECT ACTIVITIES**

### **2.5.1 Mobilization or pre-construction phase**

This phase entails mobilization of labour force, and equipment as well as acquisition of various permits as required by the law.

Other activities during this phase include;

- Topographical Survey for setting out purposes,
- Construction Materials' source Investigation,
- Material transportation, storage and material preparation,

### **2.5.2 Construction phase**

This phase entails all the necessary installations, site grading and placement of the facility components. The major activities include;

- Trench excavation and laying of 4" and 6" PVC pipes for collection of wastewater from households.
- Backfilling and paving of excavated trenches
- Construction of inspection chambers/junction boxes
- Construction of receiving chambers
- Connection of customers' latrines to the constructed network

### **2.5.3 Demobilization phase**

This phase will involve the dismantling of temporary structures such as scar forming and removing/spreading spoil materials for proper restoration of the site.

Other activities include;

- General cleanliness of the area, that is clearance of all sorts of solid wastes (plastics, wood, metal, papers, etc);
- Deposit all wastes to the authorized dumpsite;

### **2.5.4 Operation phase**

The phase entails the actual usage of the Simplified sewerage system where as the individual household will be discharging night soil directly to the system. The main task will be occasional clearance of the blockages and timely replacement of leaking pipes undertaken by DAWASA with the sole cooperation from household owners at the vicinity.

### **2.5.5 Decommissioning Phase**

Decommissioning is not anticipated in the foreseeable future as the completed facility will be serving a number of houses which at present incur many costs to dispose fecal sludge and if not so tend to discharge illegally. However, if this will happen, may entail change of use (functional changes) or demolition triggered by change of land use.

## **2.6 PROJECT DESIGN**

Mabibo Simplified sewerage system will involve construction of a simplified sewerage network discharging wastewater into the existing Mabibo wastewater stabilization ponds. The amount of sewerage that will be collected and discharged to the existing Mabibo Wastewater Stabilization Ponds will not affect the efficiency of the ponds and no overflow of wastewater. Also the design took into consideration the capacity of the existing ponds and hence identified that it is still able to accommodate more amount of wastewater. The system is planned to collect wastewater from surrounding households using 4" PVC pipes laid in shallow depth trenches. The system will operate under controlled gravity flow in accordance to designed gravity and velocity.

### **2.6.1 Design criteria**

#### **2.6.1.1 Design Criteria Development**

A shallow sewer system is a separate sewer system which utilizes gravity for conveying raw sewage from all households to an outlet downstream. It must be set deep enough to receive flows from each user but must be located so that this depth is kept to a minimum. It must have sufficient size and gradient to carry these flows. In addition, maintenance operations, public safety and convenience must be evaluated in the light of water availability and the potential for user participation. The Simplified Sewerage Network components will be sized in accordance with design criteria guidelines with a view to effectively cater for the estimated 2036 faecal sludge production horizon.

#### **2.6.1.2 Design Horizon**

The project planning has been taken to be 15 years (from 2021 to 2036), the detailed engineering design are prepared taking into account the ultimate 2036 faecal sludge network capacity requirements. For instance, the Sewer network will be designed to carry the 2036 peak hour demand; the capacity of the receiving faecal sludge treatment plant to be constructed or existing Wastewater stabilization ponds, the former will be similarly determined based

on ultimate postulated daily water demand pattern, the later will depend on the design capacity of the existing WSP.

### 2.6.1.3 Pipe materials

The most used materials for the condominial system are, PVC Domestic /PVC Reinforced. Although the PVC pipes are usually expensive than the ceramic ones, it is possible to compensate this disadvantage during the construction, due that the PVC pipes are easier and quicker to install. One must consider that the PVC pipes offer excellent flow conditions and are usually more water tight than the ceramic ones. On the other side, these ones offer a higher mechanical resistance. The Simplified network pipe will be designed for the maximum day demand of the target year 2036.

### 2.6.1.4 Minimum depth of sewer

The minimum recommended depth for the pipes is as shown in table 1 below:

Table 1: Minimum depth of sewer

Sewer type	Minimum depth
Side walk condominial branch	0.70 m
Front lot condominial branch	0.40 m
Back lot condominial branch	0.40 m
Side walk public sewer	0.80 m
Traffic road sewer	1.10 m

Wherever the sewer pipe crosses traffic road and the option of deep excavation is not feasible then concrete/steel duct should be put in use at such crossings.

### 2.6.1.5 Sewer ventilation

Ventilation to a shallow sewer network is provided through ventilation columns installed along individual water closet house connections. No ventilation columns are usually required along block and street sewers: only in cases of very long street sewer lengths (usually in excess of 5 km) , without any block sewer connections along the length, would the provision of suitable ventilation columns become necessary in order to prevent the sewage sewer from becoming septic. Such situations rarely occur in shallow sewer layouts and the

---

fact that a majority of the sewers are laid at very shallow depths in itself ensures facilitated ventilation.

#### **2.6.1.6 Inspection chambers**

In shallow sewer systems, inspection chambers are located along block and street sewers and should be used in all of these situations:

- (a) At the start of the branch
- (b) At each time the condominial branch reaches 60 m of length
- (c) At each time the public sewer reaches 100 m of length
- (d) At the connection between the internal installation and the condominial branch.
- (e) At any point where the pipe changes its direction or its slope
- (f) At any point where different upstream branches meet and discharge in the same downstream branch

The depth to invert of a sewer at the point where an inspection chamber is required will determine the dimensions of the chamber. Where the depths are shallow, usually up to 0.75 m, there is no necessity for the physical entry to the chamber for purposes of maintenance. However at, greater depths than this the chamber dimensions have to be such that the maintenance crew can physically enter the chamber.

#### **2.6.1.7 Maximum number of houses to be connected to a single sewer line**

Hydraulically over 200 houses may be connected. Given the possible economic and operational advantages of connecting a large number of houses to a single sewer line, there is little justification for limiting the number of houses that may be connected to a sewer, provided sufficient pipe capacity is available. Since water consumption and wastewater generation patterns are often different from country to country, the maximum number of houses to be connected to a sewer should be computed on the basis of the peak flow and the maximum flow capacity corresponding to the minimum gradient

#### **2.6.1.8 Minimum sewer gradient**

Practice recommends that a 100 mm diameter pipe be laid at a minimum sewer gradient of 1 in 167.

---

### **2.6.1.9 Minimum sewer diameter**

A minimum sewer diameter of 100 mm is usually recommended in fact, it i.e. definitely not advisable to increase the pipe diameter under the reduced falls proposed for shallow sewers, since this decreases the depth of flow, and solid will thus tend to be deposited frequently in the pipeline.

### **2.6.2. Technology description**

#### 2.6.2.1 Layout

To avoid deep excavations, long trunk pipes to interceptors, and large pumping stations, serious consideration is given to splitting the network into two or more smaller systems. Although network layout is also an important part of conventional design, the optimization of pipe lengths and network subdivisions takes on even greater importance in this system.

#### 2.6.2.2 Hydraulics

##### ***Design period***

Another approach to sewerage systems that can bring major benefits to the project is to reduce the design period of the sewerage system. A great advantage of using shorter term periods is that it avoids uncertainties of population growth and reduces the high costs of maintenance of large sewer systems with low flow. Other benefits of the reduced design period, are that it can also facilitate financing and achieve greater coverage with the same investment.

##### ***Design flow***

Wastewater flow quantities are necessarily lower than the quantity of water supplied because water is lost through leakage, garden watering, house cleaning, etc. To determine the expected amount of wastewater, it is important to keep records of pumpage for each day and fluctuations during the day.

Where water use information is not available, the simplified sewerage system is - designed for a minimum flow of 1.5 l/s, infiltration is assumed to be 0.05-1.0 l/s/km of pipe.

### 2.6.3. Service Connection

In the simplified design, a 60-cm connection (or inspection) box is placed between the building and the service line. All the sewers or drains from the house or building enter the box. This box is usually located under the sidewalk in the public right of way, Figure 3

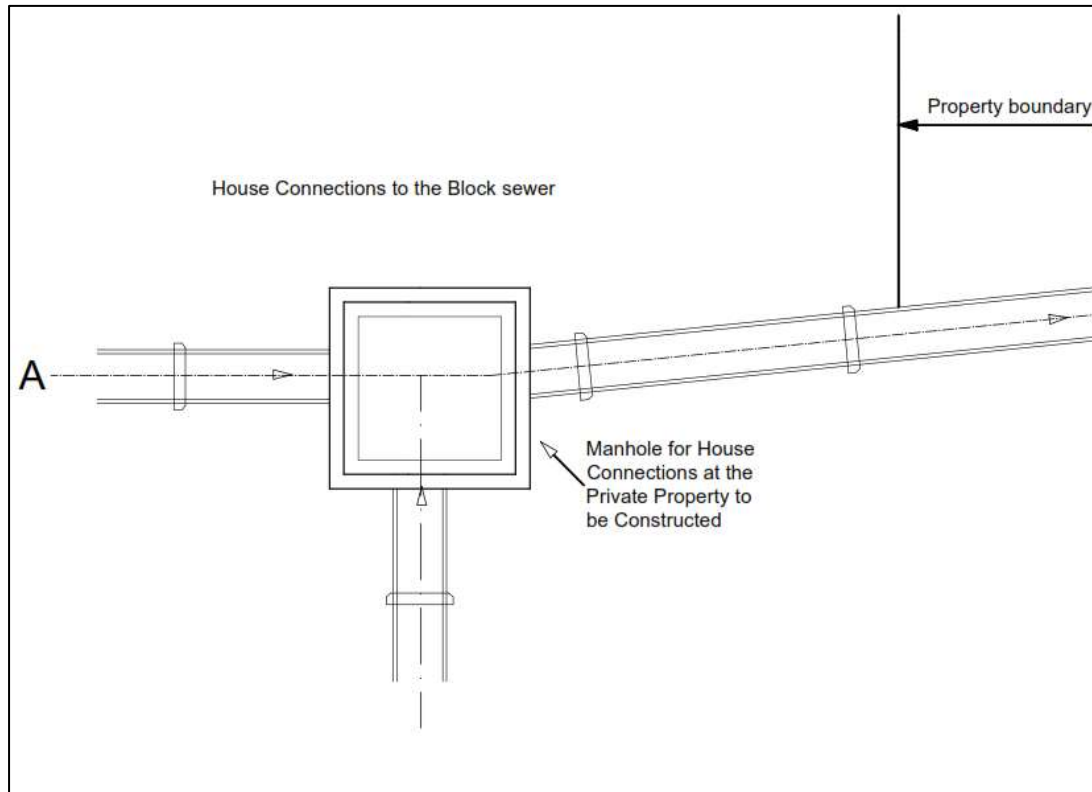

Figure 3: House connection detail

### 2.6.4 Depth of sewers

For any type of sewer connection, it is standard to have a minimum depth in which the pipes are laid should be sufficient to make house connections and have a layer of soil over the crown to protect the pipe against structural damage from external loads and frost. On simplified connections, the minimum sewer depths are usually much shallower than the conventional systems. Being as shallow as 0.65-m below sidewalks, 0.95-1.50-m below residential streets (depending on distance from the centerline of street), and 2.5-m below heavily traveled streets.

### 2.6.5 Manholes and other appurtenances

One of the most important differences between conventional and simplified sewer systems is that the former utilizes many manholes, whereas the latter type avoids its use as much as possible. The conservative criteria for manhole use contributes to the high cost of sewerage. The use of shallower depths is one way of reducing these costs, Figure 4

In conventional systems, manholes are generally located at:

- The upper ends of all laterals
- Changes in direction and slope
- Pipe junctions, except building connections
- At intervals not greater than 100m for pipes up to 600mm diameter

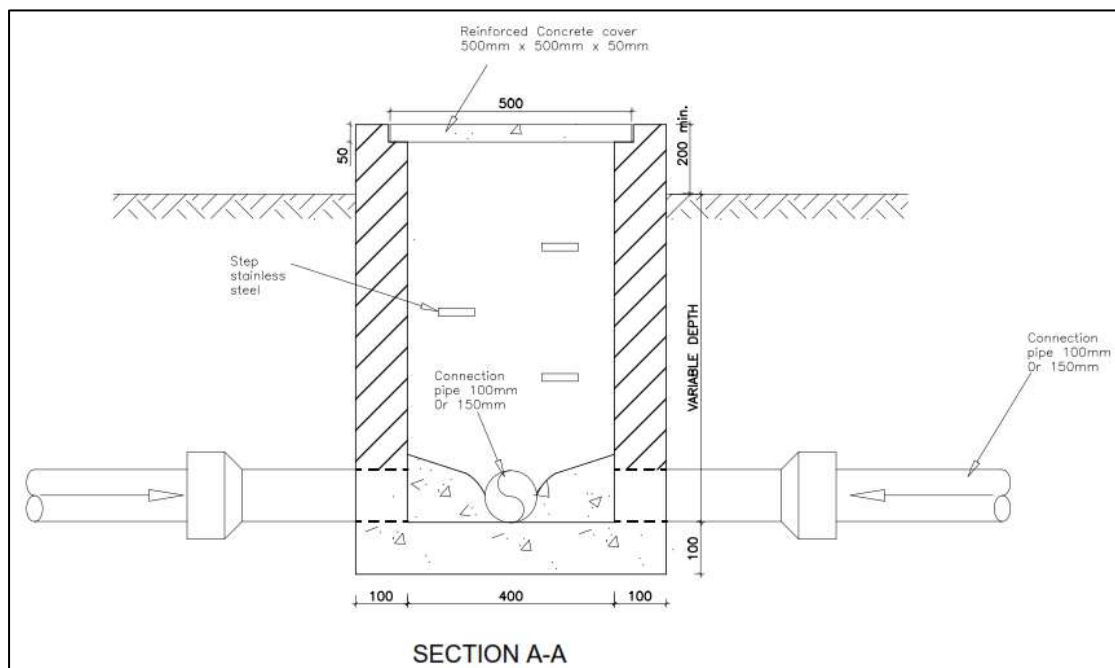

Figure 4: Standard Manhole detail

### 2.6.6 Construction Material

The types of materials used in SSS are similar to those used in conventional sewers. The most commonly used and readily available in the market are polyvinyl chloride (PVC) pipes. Additionally, PVC pipes offer the advantage of

---

longer sizes, fewer joints (i.e less infiltration), light weight, water tightness and uniformity.

### **2.6.7 Typical SSS house connection layout**

The proposed construction of simplified sewerage system at Mabibo is expected to cover the total length of about 964m, the layout of SSS at Mabibo Jitegemee Street is as shown in figure 5. Architectural and other drawings are found in Appendix III.



### **3.0 POLICIES, LEGISLATION AND INSTITUTIONAL ASPECT**

According to the fundamental principles of environment, any developmental activities of this nature such as construction of simplified Sewerage System would have socio-economic and somehow environmental impacts that must be addressed and governed in order to serve public interest and sustainable development. Given the many existing and developing environmental laws, regulations and standards in Tanzania, it is worth considering resorting to constitutional provisions to protect and manage the environment. With increasing environmental awareness in recent decades, the environment has become a higher political priority and many constitutions now expressly guarantee a 'right to a healthy environment', as well as the procedural rights necessary to implement and enforce the substantive rights granted. The public or national interest in this aspect is addressed through government Policies and regulated by Principal Acts and Regulations. The implementation of the proposed project shall touch various sectors; therefore, the developer has to comply with number of cross-sectorial policies and legislations relevant to this project. Also, the listed institutions involved in environmental management for the project is included in this chapter.

#### **3.1 RELEVANT POLICIES**

This section focuses on various policies which guide the development aspects for sustainable vision, apart from the national environmental policy, there are numbers of sector policies that are to be reviewed when executing the proposed development and these include;

##### **3.1.1 National Environment Policy 1997**

This is the main policy document governing environmental management in the country. The NEP defines environmental issues as both natural and social concerns and adopts the key principle of sustainable development. The NEP has also proposed the framework environmental legislation to be considered by the numerous agencies of the Government involved in regulating the various sectors. The NEP defines strategic plans for environmental management at all levels and provides an approach for mainstreaming environmental issues for

---

decision-making particularly the use of Environmental Impact Assessment. During implementing the project, Contracting Authority should consider the requirements of the policy including environmental protection through implementing impacts mitigation, management and monitoring plans. Henceforth the preparation of this Improved Project Brief study aims at adhering to this policy through identifying impacts, proposing mitigation, management and monitoring plans.

### **3.1.2 National Land Policy of 1997**

The National Land Policy states that “the overall aim of a National Land Policy is to promote and ensure a secure land tenure system, to encourage the optimal use of land resources, and to facilitate broad-based social and economic development without upsetting or endangering the ecological balance of the environment”. This study partly responds to this requirement.

### **3.1.3 Construction Industry Policy (2003)**

Among the major objectives of the policy, which supports a sustainable building development sector, include the promotion and application of cost effective and innovative technologies and practices to support socio-economic development activities such as sanitation, water supply, buildings, road-works, shelter delivery and income generating activities and to ensure application of practices, technologies and products which are not harmful to either the environment or human health. Proposed project is in-line with this policy as ultra-modern technology is used during construction and its operation.

### **3.1.4 National Health Policy (2003)**

The Health Policy is a vital guide towards health development of any country. It is particularly, important in a country like ours where resources and technology are more limited than in other countries, which are relatively better off in both technology and resources. This Policy is a revision of the 1990 Health Policy, which emphasized on the need for increasing community involvement in health development and improved access and equity in health and health services.

---

The Policy recognizes the challenges of consolidating the principles of the previous health policy in community involvement, improved health services provision, access and equity while addressing the different dimensions of reforms that are taking place in the Public Sector.

The proposed project will adhere to policy requirements to ensure no transmission of such communicable diseases between construction workers and the community, protect workers from all sorts of health risks and hazards; and provide adequate sanitation services within the project and ensure that its activities are not a source of health issues.

### **3.1.5 National Gender Policy of 2000**

The overall objective of the Gender and Development Policy is to promote gender equality and equal participation of men and women through facilitation of access to education, child care, and employment and decision making. Also this policy is to provide guidelines that will ensure that gender-sensitive plans and strategies are developed in all sectors and institutions. While the policy aims at establishing strategies to eradicate poverty, it emphasizes gender quality and equal opportunity of both men and women to participate in development undertakings and to value the role played by each member of society. The proposed project will adhere the requirements addressed under this policy.

### **3.1.6 National Human Settlements Development Policy (2000)**

Among the objectives of this policy is to improve the level of the provision of infrastructure and social services for the development of sustainable human settlements and to make serviced land available for shelter to all sections of the community. Such infrastructure and services constitute the backbone of urban/rural economic activities. Simplified Sewerage System is one among of the important infrastructure for the Mabibo-Jitegemee community and country at large

## 3.2 PRINCIPAL LEGISLATIONS AND REGULATIONS

The ESIA team reviewed several legislations relevant to the construction of Simplified Sewerage System. These encompass Principal Acts that support and provide guidelines to implement the intended project as discussed below.

### 3.2.1 Environmental Management Act (2004)

Among the major purposes of the EMA are to provide the legal and institutional framework for sustainable management of the environment in Tanzania; to outline principles for management, impact and risk assessment, the prevention and control of pollution, waste management, environmental quality standards, public participation, compliance, and enforcement; to provide the basis for the implementation of international instruments on the environment; to provide for the implementation of the National Environmental Policy; to provide for the establishment of the National Environmental Fund and to provide for other related matters.

Part III, Section 15(a) states that *"in matters about the environment, the Director of Environment shall coordinate various environment management activities being undertaken by other agencies to promote the integration of environmental considerations into development policies, plans, programs, strategies projects and undertake strategic environmental assessments to ensure the proper management and rational utilization of environmental resources on a sustainable basis for the improvement of the quality of human life in Tanzania"*.

Part X of the law deals with Environmental Quality Standards. Section 140 of this act states that *"The National Environmental Standards Committee of the Tanzania Bureau of Standards established under the Tanzania Bureau of Standards Act, 1975 shall develop, review and submit to the Minister proposal for environmental standards and criteria concerning; water quality; discharge of effluent into the water; air quality; control of noise and vibration pollution; sub-sonic vibrations; soil quality, control of noxious smells; light pollution; and any other environmental quality standard"* Some of these standards have already

---

been published in the government *gazette* while others are not in place. This project shall take into account all the standards specified by this act.

### **3.2.2 The Environmental Management (Fees and Charges) Regulations, 2021**

These Regulations shall apply in relation to an act or service in respect of which fees and charges are payable under the Act and Regulations made thereunder. The regulations emphasize that “a person shall not, upon payment of fees and charges prescribed in the Schedule to these Regulations, carry on any of the following”:

- Environmental Impact Assessment;
- Environmental Compliance Monitoring and Audit;
- Registration of Environmental Experts;
- Environmental Quality Standards;
- Noise and Vibrations; or
- other activities related to the environment

This project complies with the regulations since the proponent has already paid registration fees and review charges as directed by NEMC.

### **3.2.3 The Environmental Management (Control of hazardous Waste) regulations, 2021**

The objective of these regulations is to protect the environment and human health by preventing or reducing the generation of Hazardous waste, the adverse impacts of the generation and management of hazardous waste and by reducing overall impacts of resource use and improving the efficiency of such use, which are crucial for the transition to a circular economy. The regulation requires that “any person generating, collecting, storing, transporting, treating, recycling, reusing, recovering and disposing of hazardous waste or any person exercising jurisdiction under these Regulations shall, assure that there are no adverse impacts to be generated or caused by the activity conducted. Project developer will comply with the requirements of this regulation by reducing the construction materials which may generate

---

hazardous impacts, as well as proper handling of such waste such as in use of fuels for various purposes etc.

#### **3.2.4 The Environmental Management (Control of Noise and vibration) regulations, 2015**

The regulations focus on the maintenance of a healthy environment for all the people in Mainland Tanzania, the tranquility of their surrounding and their psychological well-being by regulating noise and vibration levels to prescribe the maximum permissible noise and vibration levels from a facility or activity to which a person may be exposed. The project developer will make sure that all the guidelines under this policy will be considered to ensure the healthy environment to everyone.

#### **3.2.5 The Environmental Management (Prohibition of Plastic Carrier bags) regulations, 2019**

Regulations are meant to impose a total ban on the import, export, manufacturing, sale, and use of plastic carrier bags regardless of their thickness. Plastic carrier bags has a wide definition in the Regulations, as a bag made of plastic film, with or without handles, or gussets and to which its layer is in any thickness. The Regulations also categorically state that no person shall sell or offer for sale beverages or other commodities wrapped in plastics unless the nature of such commodities require wrappings by plastics, and restricts any licensing authority from issuing any licenses after the Regulations come into force. Project developer will make sure that there will be no use of plastic bags within the project site and the whole project life time, also in case of the need of carrier bags the proponent will make sure that there will be a n alternative bags which are allowed by the regulations. For the commodities that are wrapped in plastic, then the proponent will make sure that such plastic will be handled properly.

### **3.2.6 The Environmental Management (Solid Waste Management) regulations, 2007**

The solid waste management regulation of 2007, provides general directive on management of solid waste as follows: -

Regulation detail the requirements and responsibilities for managing solid waste in Tanzania

Highlight waste minimization and cleaner production principles alongside the duty to safeguard the public health and the environment from adverse effects of solid waste. Detail permitting requirements, notably that any person dealing with solid waste as collector, transporter, waste depositor or manager of a transfer station will apply to the LGA for a permit. The local authority will also issue licenses to individuals or companies qualified to operate solid waste disposal sites; permit is required to operate an LGA waste disposal site. The proposed project is expected to generate solid waste in construction phase. Therefore, to comply with this regulation the Project developer will engage the registered solid waste collection contractor.

### **3.2.7 The Environmental Management (Water Quality) regulations, 2009**

Regulations provide for institutional and legal framework for sustainable management and development of water resources; to outline principles for water resources management; to provide for the prevention and control of water pollution; to provide for participation of stakeholders and the general public in implementation of the National Water Policy. These regulations require the sustainable management of water sources and proper use of the available sources without causing any damage towards such sources. Also, the regulations emphasize that it is every one's responsibility to conserve and preserve the available water sources in Tanzania. During all phases of the project there will be water demand, hence the project developer will make sure that there will be a sustainable use of water. Also during construction and maintenance phase the developer will make sure that the water supply pipes will not be damaged in either ways

### **3.2.8 The Environmental Management (Air Quality) regulations, 2009**

The Regulations were formed in order to: -

- Prohibit emissions and releases of hazardous substances into the environment
- Prescribe permissible emission limits and quantities of emissions of sulphur oxide, carbon monoxide, black smoke and suspended particulate matters, nitrogen oxide, ozone, hydrocarbons, dust and lead
- Empower NEMC to issue air pollutant emission permits, enforce compliance, undertake emergency prevention and issue stop orders
- Set baseline parameters on air quality and emissions based on a number of practical considerations and acceptable limits and ensure protection of human health and the environment from various sources of pollution.

The proposed project will adhere the requirements of this Act, emission limits will be monitored to the permissible limits.

### **3.2.9 The Environmental Management (Soil Quality) regulations, 2009**

These Regulations, made by the Minister of State under sections 143, 144 and 230 of the Environmental Management Act, concern soil pollution and soil quality standards and provide with respect to a soil protection permit and compliance system. They also concern measures of enforcement. The object of these Regulations is to

- Set limits for soil contaminants in agriculture and habitat;
- Enforce minimum soil quality standards prescribed by the National Environmental Standards Committee.

Also, the regulations require that, the contaminants of volatile organic compounds in habitat and agricultural soils shall comply with parameters and upper limits as prescribed and contaminants of heavy metals in habitat; agricultural soils shall comply with parameters and upper limits as prescribed and contaminants of pesticides in habitat and agricultural soils shall comply with parameters and upper limits as prescribed. Local government authority may prescribe special or specific measures and guidelines for soil conservation applicable to their respective areas of jurisdictions which are not below

standards prescribed under these Regulations. The Project developer will comply with the requirements made under these regulations.

### **3.2.10 Occupational Health and Safety Act 2003**

The provisions of this law require employers to provide decent working environment to employees to guarantee their health and safety. Occupational health and safety services are important for sustainable development of a country, as they reduce occupational accidents and diseases which can have huge economic burden to individuals, enterprises and the nation as whole. Improving health and safety of workers will significantly increase productivity at the workplaces to encourage more investments, increase job creation, higher morale, and job satisfaction hence industrial harmony. The law also entails employers to fulfil obligations of ensuring safety of the equipment's used by workers and providing proper safety gears as required.

### **3.2.11 The Water Supply and Sanitation Act No. 12 of 2009**

This is also a new legislation that provides for sustainable management and adequate operation and transparent regulation of water supply and sanitation services; provides for establishment of water supply and sanitation authorities as well as community owned water supply organizations; and provides for appointment for service providers. The main aim of this law is to ensure the right of every Tanzanian to have access to efficient, effective and sustainable water supply and sanitation services for all purposes by taking into account among others protection and conservation of water resources and development and promotion of public health and sanitation; and protection of the interest of customers. Under this law, the Minister responsible for water affairs shall establish water authority and cluster water authorities in order to achieve commercial viabilities.

### **3.12 Engineers Registration Act and its Amendments 1997 and 2007**

The Acts regulate the engineering practice in Tanzania by registering engineers and monitoring their conduct. It establishes the Engineering Registration Board (ERB), the law requires any local or foreigner engineer to register with ERB

---

before practicing in the country. Project developer will continue to comply as it has utilized the services of registered engineering firm for its structural designs which it will continue to use to supervise the construction process.

### **3.2.13 The Contractors Registration (Amendment) Act, 2008**

The Contractors Registration Act requires contractors to be registered by the Contractors Board (CRB) before engaging in practice. It requires foreign contractors to be registered by the Board before gaining contracts in Tanzania. Project Developer shall comply with the law requirement during the recruitment of contractors for project implementation.

### **3.2.14 The Architects and Quantity Surveyors Act (1997)**

The Act requires Architects and Quantity Surveyors to be involved in the project to be registered by the Architects and Quantity Surveyor Board (AQSB) before engaging in practice. It also requires foreign contractors to be registered by the Board before gaining contracts in Tanzania. Project Developer has complied with the law requirement during the recruitment of architects who have designed the project and will continue to utilize registered persons in the project implementation.

### **3.2.15 The Urban Planning Act (2007)**

The law provides for the orderly and sustainable development of land in urban areas, to preserve and improve amenities; to provide for the grant of consent to develop land and powers of control over the use of land and to provide for other related matters. Under Section 3, among others the law seeks to improve level of the provision of infrastructure and social services for sustainable human settlement development. This act established planning authorities which include the city, municipal, town and township councils in the country which have responsibilities including:

- Secure the orderly and environmentally sustainable development of area under its jurisdiction;
- Prepare general and detailed planning schemes;
- Control building densities and access to buildings;

- Recommending approval of building schemes and subdivision of plots by developers;
- Secure cooperation of all agencies, utility bodies, land owners and other bodies and institutions involved in the preparation and implementation of planning process;

### **3.2.16 Public Health Act (2009)**

Provide for the promotion, preservation, maintenance of public health with a view to ensuring the provisions of comprehensive, functional and sustainable public health services to the general public. Part III (e) of the act requires premises owners to keep their premises free of mosquitoes and other disease vectors, vermin or causative agents; Section 54 prohibits causing or suffering from nuisance likely to be injurious or dangerous to health, land, premises, air or water; Part IV (c) assigns responsibility to City council to remove or appoint an agent to collect, transport and dispose solid and liquid waste and charge fees to beneficiaries of this service and responsibilities for prescribing types of wastes and guidelines for their collection and disposal; Section 101 it gives rights to any private sewer to connect it to any available public sewer to discharge foul or storm water therefore the project may connect to and discharge sewage or storm water into the available trunk main. However, the quality of the sewage should be as per agreed with the water authority.

The Contracting Authority will ensure that the project design, construction and operation does not constitute a nuisance; meets the requirements meets public health requirements

### **3.2.17 World Bank guidelines for Environmental Management**

The main objective of this EMP is to establish a set of mitigation and monitoring measures to minimize the adverse social and environmental impacts that can take place during the implementation stage of the subproject. The measures especially focus on sensitive receptors or sensitive locations. The EMP also provides specific information about the monitoring program during construction stage including locations, frequency and reporting process. This project

complies with these guidelines as it has ESMP which contains mitigation and monitoring plans of the identified impacts.

## **4.0 BASELINE INFORMATION**

### **4.1 Introduction**

This chapter provides baseline information on existing physical, biological and socioeconomic conditions in the areas studied under this project. This baseline information is used as benchmark to identify and determine the level of potential impact due to the project. This data has to be taken into account in planning of the monitoring and mitigation requirements. The major purposes of describing the environmental settings of the study area are:

- To assess the existing environmental quality, as well as the environmental impacts of the proposed developments being studied.
- To identify environmentally significant factors that could preclude any future development.
- Additional purpose of the baseline study is to provide sufficient information to the decision makers who are unfamiliar with general location so as to develop an understanding of the project need.

### **4.2 Methodology of conducting baseline study**

The baseline information was collected from primary and secondary data sources. Primary information was collected through field study, field measurements, consultations, and satellite images. The secondary information was collected from published journals, books, authorized websites, government reports and previous studies carried out by other researchers.

Various components have been studied as a part of the baseline study these are:

- f) Physical Environment
  - g) Air Environment
-

- h) Noise Environment
- i) Water Environment
- j) Socio-Economic Environment

- The Metrological Data has been collected from secondary sources,
- The Ambient Air Quality (AAQ), samples were collected by installation of Reparable Dust Sampler and Fine Particulate Matter Sampler at different locations within the study area and analyzed to find out the existing status of air quality.
- The noise level measurements were done at different intervals of time with the help of sound level meter to establish the baseline noise levels in the impact zone.
- The land use pattern of the study area was assessed through latest satellite imagery and topographical sheets of Survey of Tanzania, followed by verification by experts.
- Socio-economic data was collected from primary source through Ward and Mtaa-level consultations. Data was also taken from secondary sources like Census of Tanzania 2012 and other demographical surveys.
- Very brief inventory of flora and fauna species present in the area was made through field visits, surveys and secondary data.

Parameters measured for the mentioned components are described in the Table 2.

Table 2: Various environmental attributes

S.No	Attribute	Parameter
1.	Land Use	Trend of land use change for different categories
2.	Noise level	Noise level in dB (A)
3.	Ambient air quality	PM10, PM2.5, SO2, NOx and VOC

4.	Socioeconomic aspects	Socioeconomic characteristics of the study area
----	-----------------------	---

### 4.3 Criteria for baseline environment study

The location of the baseline monitoring stations has been selected with respect to proposed land use and environmental susceptibility of the critical areas. The sampling locations have been selected on the basis of the following factors:

- Predominant wind directions
- Existing topography
- Drainage pattern and location of existing surface water bodies like ponds and streams;
- Location of mtaa/towns/sensitive areas

### 4.4 Physical environment

#### 4.4.1 Soil

Based on site observation and review of some secondary data sources it is revealed that, the project site has very permeable sandy loam soil with low humus quantity.

#### 4.4.2 Topography

Project site and its surrounding area is characterized with finest modified flat terrain with its lowest elevation at the western side and highest elevation at the eastern side. The maximum elevated contour is 35 m AMSL on the eastern part of the project site. While the lowest contour is 34 m in the western part of the project site. Thus rainfall runoff tends to floor from western to eastern part of the project site.

### 4.5 Meteorological Conditions

Meteorology is the key issue in order to understand the air quality. The essential relationship between meteorology and atmospheric dispersion involves wind in

---

the broadest sense. Wind fluctuations over a very wide range of time accomplish dispersion and strongly influence other processes associated with them.

Primarily and Secondary meteorological data for wind speed, direction, rainfall and air temperature were generated during the study period as described below:

#### **4.5.1 Wind**

The area is strongly dominated by winds that show a seasonal character. The wind speed from January to April ranges from 13 kmph to 20 kmph: while from May to July, it ranges from 18kmph to 20kmph, similarly, during the month of August and September, the wind velocity is between 21 kmph to 23kmph

#### **4.5.2 Rainfall**

Rainfall occurs all year round but primarily during two rainy seasons: the short rainy season from October to December and the main / long rainy season from March to May. Less rainfall occurs during January and February, and there is a long and relatively dry season from June to September. The wettest month (with the highest rainfall) is April (290 mm). The driest month (with the lowest rainfall) is August (25 mm). Thus it is expected that during April the site will not experience much particulate matter compared with August which is the driest month.

#### **4.5.4 Temperature**

The seasonal cycles of daily maximum and minimum temperature are relatively small, averaging 3.5 °C and 5 °C respectively (Figure 1). The warmest temperatures occur during January and February (~32 °C maximum and 25 °C minimum) and the coolest temperatures occur during the winter dry season (~29° and 20 °C). This small season cycle is due to Dar es Salaam being located very close to the equator and on the coast of a warm ocean which modulates the temperature through the year.

## **4.6 Hydrology**

### **4.6.1 Surface water resources:**

The major sources of portable water to the study areas are boreholes. There is no sign of surface drainage or fresh water resources, temporary or permanent (rivers, stream, and ponds) within/ near the proposed project area. Storm water drainages will be constructed on the site. The general terrain indicates surface drainage is towards the eastern side.

### **4.6.2 Ground water characteristics**

Coastal Aquifer system of which project site exist consists of lower confined unit, characterized by low mineral content and artesian (flowing) head. The upper and unconfined aquifer unit is characterized by water having considerably higher mineral contents, and with lower table which is >7 m below that of the underlying confined aquifer. There is no obvious lithological boundary between the two aquifer units, a parts from the numerous and near cyclic sand and marl beds. Consequently, a gradational transition from upper unconfined to lower confined condition is suspected. The upper 600 mm of the aquifer is dissected by faults and consists of some 40 discrete intercalations of sand marl, dipping to varying degrees in a westerly direction, depending on the degree of rotation of the individual faulted block. Overall flow direction is to the east (right), driven by artesian pressure arising from recharge in the elevated western hinterland.

## **4.7 Baseline parameters measurements**

### **4.7.1 Ambient Air Quality**

The ambient air quality at the project area was observed to be good because the area is for residential purposes only, just because of daily activities there will be particulate matter like dust.

#### **4.7.2 Noise and Vibration**

The noise and vibration levels at the project site are rated negligible as the only source of noise at the project site are motor vehicles using the street feeder road adjacent to the project area.

### **4.8 Social Economic Environment**

#### **4.8.1 Population and Demographic Patterns**

Ubungo Municipality is located in the North West part of the city, covering an area of 260.40 km<sup>2</sup>. According to 2012 population census the municipality had a population of 845,368 where male was 409,149 and 436,219 females. With population projection of 2016 Ubungo municipality has a total population of 1,031,349 whereby male are 499,161 and female are 532,188 with a growth rate of 5.0% per annum with a population density 4,911 people per square kilometer. There municipal have 257,837 households with the average of 4 persons per household. The majority of the residents are involved in petty business, fisheries, livestock keeping and agriculture including horticulture

#### **4.8.2 Ethnic composition**

The main native' ethnic groups in the project area are Zaramo and Ndengereko but due to urbanization many people of different ethnicity have migrated in making heterogonous tribal composition whereby no single ethnic group accounts for more than 25% of the total population. The rapid economic growth of the city is also what attracts influx of people from different regions of the country and outside the country to Dar es Salaam.

#### **4.8.3 Occupation and Income**

Most of the people in the project area involve themselves as either employed or self-employed. In that case the buildings in the project area have different uses i.e. residential, institutional and commercial and others by private or individuals where most of them deal with business and community services. Some of economic activities involved in the project area are: -

- Hotels
- Livestock keeping especially chicken and dam cattle
- Import and export businesses
- Transportation services e.g. daladala, bodaboda and bajaji
- Shops
- Office works e.g. consultants
- Clearing and forwarding
- Agro businesses
- Medical businesses
- Handcraft Businesses
- Banking businesses
- Construction Business

These activities play a significant role to the Dar es Salaam City economy in terms of revenue and in provision of job opportunities to the residents. Agriculture is still an important economic activity, but it is dealt in the peri-urban area of the Project area.

The Dar es Salaam City Profile, 2016, indicates that GDP per capita for Dar es Salaam to be TZS 900,086 with 35% of the population earning an average low income of TZS 387,319 per annum (about TZS 92,000 per month).

#### 4.8.4 Education

Ubungu municipality had a total of 183 registered school of which 118 are primary schools and 64 of them are government owned and 54 owned by private sector, table 3. Also, there are 65 secondary schools of which 26 are government owned and 39 are privately owned. Ubungu is also the educational Centre of Tanzania with Famous Educational institutions which are: University of Dar es Salaam, Ardhi University, St. Joseph university and the EASTC.

Table 3: Distribution of public secondary schools in Ubungo Municipal

Wards	NO	Name of secondary schools
Kwembe	2	Kwembe, Luguruni

Kibamba	6	Kibamba, Kiluvya, Gogoni, Hondogo B, Kimbweheri and Kimbwegere.
Goba	5	Goba, Fahari, Matosa, Goba mpakani, Kinzudi
Mbezi	2	Mbezi inn, Mpijimgohe
Msigani	2	Malamba Mawili, Temboni Government
Kimara	-	-
Makaburi	2	Y.R. Makamba
Manzese	1	Manzese
Makurumla	1	Makurumla
Mabibo	1	Mabibo
Sinza	1	Mugabe
Mburahati	1	Mburahati
Ubungo	1	Urafiki
Saranga	2	Kingongo sarangi
Total	27	

#### 4.8.5 Health service

Ubungo Municipal council has a total of 68 health facilities of which 17 are government owned, while remaining 51 are owned by private organizations. Sinza hospital is the only hospital owned by government providing health services within the Municipal. This hospital is called a district hospital which is providing services to 1000 to 1500 in and out patient per day. Table 4 shows a list of health facilities available in Ubungo Municipal Council.

Table 4: Distribution of health facilities in Ubungo Municipal

HEALTH FACILITY LEVEL	GOVERNMENT	PRIVATE	TOTAL
Hospital	1	4	5

---

Health centers	0	6	6
Dispensaries	16	41	57
<b>Total</b>	<b>17</b>	<b>51</b>	<b>68</b>

#### 4.8.5 Water and Sanitation

The main source of water for Ubungo Municipality is DAWASA which contributes 68% of water being consumed daily and the rest is contributed by deep and shallow wells owned by both private and public. The other source of water is 17 boreholes which are managed by different institutions, water user associations (water committees) and private owned boreholes.

##### **Waste Management**

Principally, waste management in Tanzania is liable directly to the local authority's responsibility. The local Government (Urban authorities) Act 1982 imposes under urban authorities the responsibility "to remove refuse and filth from any public or private place" (sect. 55 g) and to provide and maintain public refuse containers for the temporary deposit and collection of rubbish.

The Municipal Council plays an important role in financing, planning and providing waste collection and disposal services. Under the Municipal Council, waste management belongs to the structure of the Waste Management Department, but other departments such as Works, Health and urban planning carry out part of its operation.

##### ***Generation of Solid Waste.***

Ubungo Municipality is estimated to generate about 827.4 tons of waste per day which gives 302,001 per year, the generation of solid waste is mainly from residential areas, industrial areas, institutions, commercial establishments like, markets and other informal sectors comprise this amount. The per capita waste generation rate was found to be 0.80 kg/cap/day in Ubungo municipality. The waste generation in the municipality is shown in the table 5.

Table 5: Waste Generation and collection in Ubungo Municipality

Types of waste	Amount generated	Tones/day
Household waste	661	Tones/day
Commercial waste	12.4	Tones/day
Institutional waste	4.9	Tones/day
Market waste	16.5	Tones/day
Streets waste	0.74	Tones/day
Informal sector waste	131.6	Tones/day
TOTAL	827.4	Tones/day

#### Waste Collection

Solid waste collection in Ubungo municipality is carried out by both the Municipal, some private companies, community-based organizations and informal sectors. Apart from collection activities, the Municipality is also responsible for supervising the SWM systems available. On a daily basis Ubungo collect around 422 tonnes per day which is to the collection rate of 51% of all generated wastes.

#### Waste Transportation

Currently the transportation of solid waste is done by both the Municipal council and the private sectors. Trucks owned by the private sectors including contractors, Community groups and NGO's. Other equipment which are used to collect the waste and transportation is the Trailers owned by municipal Council and these are pulled by Municipal Tractors and other private owned tractors which are hired.

### 4.8.6 Energy

Dar es Salaam city dwellers depend on different sources of energy such as electricity, charcoal, firewood and gas, also stand-by generators are used during power outages. The main source of power for lighting, business and industry is electricity, which is generated, transmitted and supplied by a sole

power utility, Tanzania Electric Supply Company (TANESCO). Residents commonly use electricity, charcoal, gas for cooking and lighting. A large number of service outlets use charcoal and gas for cooking, some use kerosene stoves.

#### **4.8.6 Housing**

Life forms at the proposed project site are mixed, such that there are residential, institutional and commercial activities. Housing and settlement in the area shows that the majority of buildings have houses roofed with corrugated iron sheets while few buildings are covered with tiles. The walls of building are of concrete blocks and a small proportion of households have houses with walls built from burnt bricks and stones. On the increase is the number of houses built and later covered with glass. On the other hand, the houses of most households have tiles floors followed by those which have cement screed.

## 5.0 STAKEHOLDER VIEWS ON THE PROPOSED PROJECT

During this study, different stakeholders were consulted. Among these include the Ubungo Municipal Council and community at Mabibo (see Figure 6). Consultations were made through meetings.



Figure 6: Stakeholder's consultation meeting at Ubungo Municipal office and Mabibo jitegemee community

During the meeting, the consultant gave a brief explanation on the proposed Simplified sewerage system. The project description covered proposed location, type and design (a typical design was displayed). The stakeholders were given chance give their views on the project. Moreover, the consultant offered chance to clarify issues where stakeholders wanted to be given more explanations. The comments by stakeholders were analyzed and incorporated in the design of mitigation measures. Table 6 summarizes the issues raised. The names of the stakeholders consulted are given in Appendix II.

Table 6: Stakeholders issues and concerns

Institution	Name	Position	Issues/ concerns	Response
UBUNGO MUNICIPAL COUNCIL, MANZESE WARD	Diana Juma	Ward Health Officer	-The proposed SSS at Mabibo will reduce the extent of uncontrolled sewage discharge	Section 7.3.1.1

## **6.0 PROJECT REQUIREMENTS AND WASTE GENERATION**

### **6.1 Project requirements**

#### **6.1.1 Construction materials and labour force**

The main materials for construction of Simplified sewerage system include cement, aggregates (stones), water, steel, sand, timbers, blocks, PVC pipes, and gravels. All materials are available in the local sources in Tanzania and will be sourced from the licensed and recognized suppliers or sources. The estimated quantities of the materials to be included in the BoQ.

#### **6.1.2 Labour force**

The labour force will be determined by the Contractor; nevertheless, it is projected that during the construction phase the project will require not less than 100 workers both skilled and non-skilled laborers for each phase of project construction. During operational phase it is estimated that 30 unskilled workers will be retained for operating the system.

#### **6.1.3 Machinery and Equipment**

The proposed project development will employ various standard construction equipment and machinery. Equipment expected to be used during the construction works are Tippers, Concrete Mixers, poker vibrators, Wheel barrow, Compactor, etc. All equipment and machineries for construction works needed by the proposed project will be determined when the bill of quantities (BoQ) and selection of Contractor is finalized. These equipment shall be temporary and shall be demobilized once project is completed. On the other hand, the hand tools which will be used during construction phase constitutes; Shovels, hoes, hammer, pickaxe, buckets etc.

### **6.2 Wastes generation**

The major wastes generation associated with the project are solid wastes and liquid waste. The solid wastes so produced will be collected and properly disposed at the collection points ready for transportation to the dumpsite.

### 6.2.1 Liquid waste management

During the maximum operation phase a total of 1,170m<sup>3</sup> per day of liquid waste is estimated to be received at the downstream receiving chamber of the Fecal sludge treatment facility close to the project site.

### 6.2.2 Solid waste management

From experience point of view, households connected to the simplified sewerage system tend to throw solid wastes especially used sanitary pads into their toilet sinks thinking flushing will help but the results has always been immediate blockage.

The project design will ensure installation of garbage screen at each household level to prevent the system blockage from single individual's fault. This among others will render the household with the blockage to ensure the situation is well and timely handled at their own costs.

Therefore, solid wastes should be properly disposed at the collection points waiting for solid waste pickup trucks. Table 7 below shows solid and liquid wastes to be generated by the project and the methods of their disposal.

Table 7: Management of construction and operation wastes

Solid waste			
Type of waste	Sources	Estimated Quantity (Kg)	Disposal / Management procedure
Biodegradable materials mainly domestic waste (food, paper, wood etc.)	- Construction crew	30-50	Accessible litter bins within the camp site and later to the city waste disposal system (engage a private company)
Non- biodegradable materials (plastic, glass)	- Construction crew	5-10	Recycling/ reuse (Plastics to be sent to plastic recyclers and glass bottles to be sent to glass recyclers)
Liquid waste			
Type of waste	Sources	Estimated Quantity (m <sup>3</sup> )	Disposal / Management procedure

<ul style="list-style-type: none"> <li>- Excreta (domestic) human</li> <li>- Grey water /cleaners</li> </ul>	<ul style="list-style-type: none"> <li>- Toilets and floor cleaning</li> </ul>	<p>1,170</p>	<p>Use of existing septic tanks and pit latrines and after construction will use the Simplified sewerage system for further treatment downstream</p>
--	--	--------------	--

## **7.0 POTENTIAL IMPACTS**

### **7.1 Mobilization Phase**

#### **7.1.1 Positive impacts**

##### **7.1.1.1 Employment opportunities**

Labour force for the project will be originated from Mabibo Ward and the surrounding communities in Ubungo areas. Even though during construction the employment will be on short term basis, employees will have been benefiting from the project. Some will witness their incomes and livelihood improvement.

#### **7.1.2 Negative impacts**

##### **7.1.2.1 Noise pollution**

Noise pollution is likely to occur due to the application of construction equipment and generators at the site.

#### **Mitigation Measure**

- The proponent shall maintain equipment in good running conditions to ensure that ambient noise level and vibrations pollution into the environment is very minimum to comply with Tanzania standards.
- The noisy construction activities will be scheduled at normal working hours. Regular inspection and maintenance of construction vehicles and equipment will be done to ensure that they have mufflers installed and worn parts are replaced

### **7.1.2.2 Air Pollution from dust emission**

Air pollution is likely to occur due to the emission of suspended particulate matter (dust) to the atmosphere from the construction activities.

#### **Mitigation Measure**

- Mixing equipment shall be sealed properly and vibrating equipment will be equipped with dust removing devices.
- Also all vehicles that generate excessive black smoke will not be used.
- Adequate training and use of personal protective equipment (PPE) such as eye glasses and dust masks will be ensured in order to reduce risks associated with dust.

## **7.2 Construction Phase**

### **7.2.1 Positive Impacts**

#### **7.2.1.1 Employment opportunities**

Labour force for the project will be originated from Mabibo Ward and the surrounding communities in Ubungo areas. Even though during construction the employment will be on short term basis, employees will have been benefiting from the project. Some will witness their incomes and livelihood improvement.

#### **7.2.1.2 Increased socio-cultural interaction**

Increased socio-cultural interaction is another anticipated positive impact. The implementation of the project will bring many people from different cultural backgrounds. The interactions may bring about social changes in the communities around the project areas. Interaction with technocrats as a result of new immigrants (customers) into the area will stimulate adoption of the new technologies.

### **7.2.1.3 Increased Revenue to the nation through taxes, both direct and indirect**

DAWASA is expected to increase its revenue collection on implementing this project. This will be through monthly payment of sanitation services by the respective household. The revenue collected will contribute towards expansion of the water supply and sanitation service within DAWASA service area.

### **7.2.1.4 Cost reduction for sewage management**

The proposed facility will make it easier for the Institutions and households which at present incur unbearable costs for proper dislodging the septic tanks when full. That simply means the households in the vicinity and the institutions will benefit through direct connection to the downstream treatment facility depending on the nature of topography.

## **7.2.2 Negative impacts**

### **7.2.2.1 Increased HIV/AIDS and other sexual related diseases:**

Local communities surrounding the project area have to be aware of the fact that HIV/AIDS is present in their areas but accede to it not being at an alarming rate. The communities were worried that with an influx of people into the project area the pace of spread will accelerate especially during the construction phase.

#### **Mitigation Measures**

- Contractor shall enforce a code of conduct in the project area to encourage respect for the local community and to maintain self-cleanliness of the working area at all times.
- The contractor shall deploy locally available labour to reduce risk of spreading communicable diseases (especially STDs).
- In order to prevent more HIV/AIDS infection, during the implementation phase, the project should include information education and communication component (IEC) in its budget. This will help to raise more awareness on HIV/AIDS, and means to suppress its incidence.

- A safety, health and environment induction course shall be conducted to all workers, putting more emphasis on HIV/AIDS, which has become a national disaster.

#### **7.2.2.2 Land degradation and increased erosion**

Establishment of new facility within the project area might result into land degradation and promote soil erosion.

##### **Mitigation Measures**

- Unnecessary trench excavation close to the buildings and sensitive re-alignments shall be avoided.
- Lined drainage channels at sensitive terrains shall be provided to control speed and volumes of storm-water.
- The contractor should plant grass or any other vegetation cover to minimise exposed soil surface.
- Directing flow to properly designated channels within the facility site.
- Timely backfilling
- Paving the erosion prone alleys

#### **7.2.2.3 Noise pollution**

Noise pollution is likely to occur due to the application of construction equipment and generators at the site.

##### **Mitigation Measure**

- The proponent shall maintain equipment in good running conditions to ensure that ambient noise level and vibrations pollution into the environment is very minimum to comply with Tanzania standards.
  - The noisy construction activities will be scheduled at normal working hours. Regular inspection and maintenance of construction vehicles and equipment will be done to ensure that they have mufflers installed and worn parts are replaced
-

#### **7.2.2.4 Air Pollution from dust emission**

Air pollution is likely to occur due to the emission of suspended particulate matter (dust) to the atmosphere from the construction activities.

##### **Mitigation Measure**

- Mixing equipment shall be sealed properly and vibrating equipment will be equipped with dust removing devices.
- Also all vehicles that generate excessive black smoke will not be used.
- Adequate training and use of personal protective equipment (PPE) such as eye glasses and dust masks will be ensured in order to reduce risks associated with dust.

#### **7.2.2.5 High Risk of Health associated with construction work**

Construction activities exposes the workers to a lot of risks for example risk of getting into contact with fecal sludge matter, injuries, COVID-19 pandemic etc

##### **Mitigation measure**

- The project proponent shall ensure that all personnel are provided with appropriate protective gear.
  - All works shall be planned and conducted in accordance with relevant OHS Guidelines. First Aid Kit as well as regular medical check-ups for the workers will be provided during the entire working hours.
  - Adequate number of firefighting equipment/extinguishers will be provided in every few distance to help putting off fire in case of occurrence.
  - Excavated pits should be protected by warning tape and guardrails to prevent workers and passersby from falling
  - Provision of hand washing equipment and soap at every entrance and exit and at random passage ways within the construction site.
  - Ensure all workers to take precautionary measures against COVID-19 by washing hands with soap frequently, practicing social distancing and using face masks of their preference.
-

### **7.2.2.6 Waste generation during construction**

A lot of waste will be generated especially during construction stage. For example, pipework is likely going to produce some plastics which need to be disposed of. Construction of waste water chambers will both generate wastes. Other wastes will be generated from cleaning of construction equipment and containers like mixers and paint buckets.

#### **Mitigation measures:**

- Stick to the design specifications
- Provide waste containers
- Provide training to workers and orient them towards environmental protection values

### **7.2.2.7 Sewer leakage/overflow**

Sewer leakage/overflow is likely to occur during house connections to the newly constructed system.

#### **Mitigation Measure**

- Ensure proper methodology for house connections
- Ensure availability of a standby cesspit emptier to desludge the pit latrines and septic tanks before connection
- Sensitization of the local community to avoid puncturing the sewer pipes
- Ensure sealed and watertight connection at each pipe junctions

### **7.2.2.8 Traffic Jam**

Activities related to construction works will undoubtedly induce additional vehicular traffic along roads leading to the construction site. Related issues of vehicle congestion and reckless driving by truck drivers delivering construction materials and supplies to the site and the trucks/Vehicles entering or leaving the project site will be sources of potential traffic congestion and accidents to road users and pedestrians. It is important to note; however, that the equipment and vehicles needed for the construction of the proposed project is low compared to other development projects.

---

## **7.3 Operation Phase**

### **7.3.1 Positive Impacts**

#### **7.3.1.1 Improved social-economic livelihood and dignity within the beneficiary society**

The project will improve the living conditions in Ubungo Municipal specifically Mabibo ward whereby the project operation phase will do away with illegal faecal sludge dislodging especially during rainy season or during the night. The monthly charged fee for each connected household will be such as affordable by the intended customer. Thus, there will be increased money circulation that result into increased income consequently better standard of living of people in the project area.

#### **7.3.1.2 Increased Revenue to the nation through taxes, both direct and indirect**

DAWASA is expected to increase its revenue collection on implementing this project. This will be through monthly payment of sanitation services by the respective household. The revenue collected will contribute towards expansion of the water supply and sanitation service within DAWASA service area.

#### **7.3.1.3 Cost reduction for sewage management**

The proposed facility will make it easier for the Institutions and households which at present incur unbearable costs for proper dislodging the septic tanks when full. That simply means the households in the vicinity and the institutions will benefit through direct connection to the downstream treatment facility depending on the nature of topography.

#### **7.3.1.4 Reduce risk of soil and groundwater pollution**

Construction of simplified sewerage system will reduce the contamination/pollution of soil and groundwater because the waste water from toilets will directly flow to the ponds. The system will also reduce the desludging into the open storm water channels especially during rainy season.

## 7.3.2 Negative Impacts

### 7.3.2.1 Sewer leakage/overflow

Sewer leakage/overflow is likely to occur due to the possibility of blockage or pipe rupture resulted from human activities.

#### Mitigation Measure

- Ensure timely maintenance of the blocked sewer section.
- Installation of screen at receiving individual household interceptor Manhole.
- Sensitization of the local community to avoid dumping solid wastes into the toilet sinks.
- Installation of flushing mechanism so as to scour any possible deposited silt/sludge.
- Inspection of the sewer lines and manholes for any possible pre-mature leakage/overflow

## 8.0 ACTION PLAN FOR PREVENTION AND MANAGEMENT OF ACCIDENTS DURING IMPLEMENTATION STAGE

The project shall be implemented in compliance to labour laws in Tanzania, in particular, the Occupational Health and Safety Act (2003). Clauses to protect the health and safety of workers shall be included in the contract documents for implementation stage.

### 8.1 Occupational Health and Safety

The proponent is committed to protect the health and safety of its employees and those of its contractors, to ensuring that activities are conducted in a manner that protects the environment and people. The Contractor shall provide and enforce the use of appropriate personal protective equipment for all workers e.g. overalls, gloves, masks, etc. (wherever required).

Tanzanian/international construction standards will be followed for quality and safety to workers. First aid facility will be installed at the construction site.

### **8.1.1 Emergency preparedness Plan**

The proponent is committed to ensure the availability of the emergency preparedness plan in place prior to commencement of construction phase. Among others the plan should contain; identified risks, Team Build up, Availability of critical information, updated alert and response procedures and ensuring that the plan is working by putting it to some tests.

## **8.2 Security**

The whole proposed project will take care of security matters of the site by fencing the storage area and provide gates for entrance and exit purposes. The project proponent shall have a 24 hours security services from a private company to secure the whole project premise at the site. The project proponent will install the best firefighting system at the site. The purpose of fire protection is to protect life, goods, and activities within the project site.

The following are some of the active and passive fire-fighting equipment that will be employed;

- Portable Fire Extinguishers

## **8.3 Monitoring, Maintenance and repair**

The management of the facility will be upon both DAWASA and Ubungo Municipal Council to ensure the approved design or plan is implemented accordingly. Furthermore, provision of basic services will be executed at high quality as intended.

## **9.0 ENVIRONMENTAL AND SOCIAL MANAGEMENT PLAN**

### **9.1 Environmental and Social Management Plan**

The Environmental and Social Management Plan (ESMP) presents the implementation schedule of the proposed mitigation measures for both environmental and social impacts. The ESMP for the proposed Construction of

---

---

Simplified Sewerage System at Mabibo jitegemee area is summarized in Table 8. The ESMP also indicates environmental costs needed to implement the recommended mitigation measures. The site selection process has been done, however engineering designs are being prepared and will soon be incorporated with the mitigation measures recommended in this report. Additional recommendations are provided in the ESMP to enable the Simplified sewerage system to be constructed and operated in environmentally friendly manner.

DAWASA in collaboration with Ubungo Municipality shall be the main implementer of the ESMP through. The environmental measures incorporated in the detailed engineering design will be attached to the Bills of Quantities and Contract Documents. Moreover, there will be an Environmental, Social, Health and Safety (ESHS) Code of Conduct to be signed by the Contractor(s) to show their commitment in the implementation of the Environmental, Social, Health and Safety. The implementation of the Code will be supervised by DAWASA or his consultant.

The ESHS Code is a set of Guidelines attached to the Bidding Document and Contract to be adopted by Contractor during project implementation. It contains the commitment and obligations of the Contractor and its subsidiaries (i.e. Sub-Contractors and staff) to undertake construction activities in accordance with all applicable Laws, Rules, and Regulations. The Contractor and its subsidiaries shall comply with the Code of Conduct with high ethical standards. Failure to observe the Code, will subject the firm to disciplinary action, including Contract termination. Violation of the Code, is violation of Law which may result to civil and/or criminal penalties to Contractors, Supervisors or Firm.

Some of the issues to be included in the ESHS shall include;

- Site specific **ESMP, HSMP,**
- Traffic Management Plan (**TMP**), **where applicable**
- HIV/AIDS Awareness Program,
- Occupational Health and Safety Awareness Program.
- Sexual Harassment Prevention Policy

- Child Labour Prevention Policy

The environmental and social mitigation and enhancement measures incorporated in the detailed engineering design will be attached to the Contract Documents. The Contractor shall take stock of the contents of the Project Brief.

Table 8: Environmental and Social Management Plan for the Proposed Construction of Simplified sewerage system at Mabibo jitegeme area, Ubungo Municipal

Impact	Mitigation Measure	Responsible Institution	Estimated (TZS)
Increased waste generation	<ul style="list-style-type: none"> <li>○ Stick to the design specifications</li> <li>○ Provide waste containers</li> <li>○ Provide training to workers and orient them towards environmental protection values</li> </ul>	Contractor/DAWASA/Ubungo Municipal Council	2,000,000.00
Noise pollution during construction	<ul style="list-style-type: none"> <li>○ The proponent shall maintain equipment in good running conditions to ensure that ambient noise level and vibrations pollution into the environment is very minimum to comply with Tanzania standards</li> <li>○ All construction works will be scheduled at normal working hours.</li> <li>○ Proper inspection and maintenance of construction vehicles and equipment will be done to ensure that they have mufflers installed and worn parts are replaced</li> </ul>	Contractor/DAWASA/Ubungo Municipal Council	1,000,000.00
Increased HIV/AIDS and other STD	<ul style="list-style-type: none"> <li>○ The contractor shall enforce a code of conduct in the project area to encourage respect for the local community and to maintain self-</li> </ul>	Contractor/DAWASA/Ubungo Municipal Council	5,000,000.00

	<p>cleanliness of the working area at all times.</p> <ul style="list-style-type: none"> <li>○ The contractor shall deploy locally available labor to reduce the risk of spreading communicable diseases (especially STDs).</li> <li>○ To prevent more HIV/AIDS infections, during the implementation phase, the project should include an information education and communication component (IEC) in its budget. This will help to raise more awareness on HIV/AIDS and means to suppress its incidence.</li> <li>○ A safety, health, and environment induction course shall be conducted for all workers, putting more emphasis on HIV/AIDS, which has become a national disaster.</li> </ul>		
<p>Land degradation and increased erosion</p>	<ul style="list-style-type: none"> <li>○ The contractor should pave the walkways prone to erosion whose quantities are shown in the BoQ</li> <li>○ To obtain the construction materials official negotiations should be</li> </ul>	<p>Contractor/DAWASA/Ubungo Municipal Council</p>	<p>25,000,000</p>

	performed with wards leaders to avoid conflict.		
Noise pollution during construction	<ul style="list-style-type: none"> <li>○ The proponent shall maintain equipment in good running conditions to ensure that ambient noise level and vibrations pollution into the environment is very minimum to comply with Tanzania standards</li> <li>○ All construction works will be scheduled at normal working hours.</li> <li>○ Proper inspection and maintenance of construction vehicles and equipment will be done to ensure that they have mufflers installed and worn parts are replaced</li> </ul>	Contractor/DAWASA/Ubungo Municipal Council	1,000,000.00
Dust generation during construction	<ul style="list-style-type: none"> <li>○ Mixing equipment shall be sealed properly and vibrating equipment will be equipped with dust-removing devices.</li> <li>○ Also, all vehicles that generate excessive black smoke will not be used.</li> <li>○ Adequate training and use of personal protective equipment (PPE) such as</li> </ul>	Contractor/DAWASA/Ubungo Municipal Council	5,000,000.00

	eyeglasses and dust masks will be ensured to reduce risks associated with dust.		
Health Risks associated with construction works	<ul style="list-style-type: none"> <li>○ The project proponent shall ensure that all personnel is provided with appropriate protective gear.</li> <li>○ All works shall be planned and conducted following relevant OHS Guidelines. First Aid Kit as well as regular medical check-ups for the workers will be provided during the entire working hours.</li> <li>○ An adequate number of firefighting equipment/extinguishers will be provided every few distances to help to put off the fire in case of occurrence.</li> <li>○ Excavated pits should be protected by warning tape and guardrails to prevent workers from falling</li> <li>○ Adhere to good maintenance</li> </ul>	Contractor/DAWASA/Ubungo Municipal Council	6,000,000.00
Noise pollution during construction	<ul style="list-style-type: none"> <li>○ The proponent shall maintain equipment in good running conditions to ensure that ambient noise level and vibrations pollution into the</li> </ul>	Contractor/DAWASA/Ubungo Municipal Council	800,000.00

	<p>environment is very minimum to comply with Tanzania standards</p> <ul style="list-style-type: none"> <li>○ All construction works will be scheduled at normal working hours.</li> <li>○ Proper inspection and maintenance of construction vehicles and equipment will be done to ensure that they have mufflers installed and worn parts are replaced</li> </ul>		
Health Risks associated with construction works	<ul style="list-style-type: none"> <li>○ The project proponent shall ensure that all personnel is provided with appropriate protective gear.</li> <li>○ All works shall be planned and conducted following relevant OHS Guidelines. First Aid Kit as well as regular medical check-ups for the workers will be provided during the entire working hours.</li> <li>○ Adhere to good maintenance</li> </ul>	Contractor/DAWASA/Ubungo Municipal Council	Depend on the operational manual
<b>Total</b>			<b>45,800,000.00</b>

## **10.0 MONITORING PLAN**

### **10.1 Environmental Monitoring**

The national EIA guidelines require the developer to prepare and undertake monitoring plan of implemented development projects. Monitoring is needed to check if and to what extent the impacts are mitigated, benefits enhanced and new problems addressed. Recommendations for monitoring have been included in the Table 9. The monitoring plan also assigns responsibilities for different actors. Moreover, the ward and street environmental committees will shoulder the long-term monitoring of the project.

Table 9: Monitoring Plan for the Proposed Construction of Simplified sewerage system at Mabibo Jitegeme Mabibo Ward Ubungo Municipality

Environmental impact	Mitigation Measure	Parameter	Monitoring Frequency	Sampling Area	Measurement Unit	Method	Target Level/Standard	Responsibility for monitoring	Estimated Annual (or once cost (TZS)
<b>Mobilization Phase</b>									
Respiratory diseases due to dust emission	-Dust suppression -Use of efficient equipment	Presence of nuisance dust PM2.5 PM10	Daily	Immediate working area	µg/m <sup>3</sup>	Physical -visual	25 µg/m <sup>3</sup> for PM2.5 and 50 µg/m <sup>3</sup> for PM10	Contractor/ Mabibo Ward	1,000,000.00
Air Quality	-vehicles that generate excessive black smoke will not be used. -use of personal protective equipment (PPE)	Smell and Odor	Daily	Around the Inspection chambers	Presence of smells	Smelling (nasal)	Absence of nuisance smells	Mabibo Ward/DAW ASA/Ubungo Municipal Council	2,500,000.00
Land pollution due to Waste Generation	-Provision storage containers	Amount of waste generated	Weekly	At the working area	Kg, tones and Cubic Meters for liquid waste	Physical measurement or estimation	All waste contained	Contractor/ Mabibo Ward/DAW ASA/Ubungo Municipal Council	1,000,000.00
Accidents, injuries, and Health risks	-Provision of PPEs	Number of health risk recorded	Daily	At working area	Accidents/injuries	Counting and records	NO/Minimum accident	Contractor/ Mabibo Ward/DAW ASA/Ubungo	2,000,000.00

**Comprehensive Project Brief of the Proposed construction of Simplified sewerage system at Mabibo jitegeme area**

Environmental impact	Mitigation Measure	Parameter	Monitoring Frequency	Sampling Area	Measurement Unit	Method	Target Level/Standard	Responsibility for monitoring	Estimated Annual (or once cost (TZS)
								o Municipal Council I	
HIV/AIDS	-Enforce of code of conduct	Number of HIV/AIDS Cases	Monthly	Workers	Training	Numbers	No Cases	Contractor/ Mabibo Ward/DAW ASA/Ubung o Municipal Council I	5,000,000.00
<b>Construction phase</b>									
Respiratory diseases due to dust emission	-Dust suppression -Use of efficient equipment	Presence of nuisance dust PM2.5 PM10	Daily	Immediate working area	µg/m <sup>3</sup>	Physical -visual	25 µg/m <sup>3</sup> for PM2.5 and 50 µg/m <sup>3</sup> for PM10	Contractor/ Mabibo Ward	1,000,000.00
Air Quality	-vehicles that generate excessive black smoke will not be used. -use of personal protective equipment (PPE)	Smell and Odor	Daily	Around the Inspection chambers	Presence of smells	Smelling (nasal)	Absence of nuisance smells	Mabibo Ward/DAW ASA/Ubung o Municipal Council	2,500,000
Land pollution due to Waste Generation	-Provision storage containers	Amount of waste generated	Weekly	At the working area	Kg, tones and Cubic Meters for liquid waste	Physical measurement or	All waste contained	Contractor/ Mabibo Ward/DAW ASA/Ubung	1,000,000

**Comprehensive Project Brief of the Proposed construction of Simplified sewerage system at Mabibo jitegeme area**

Environmental impact	Mitigation Measure	Parameter	Monitoring Frequency	Sampling Area	Measurement Unit	Method	Target Level/Standard	Responsibility for monitoring	Estimated Annual (or once cost (TZS)
						estimation		o Municipal Council	
Accidents, injuries, and Health risks	-Provision of PPEs	Number of health risk recorded	Daily	At working area	Accidents/injuries	Counting and records	NO/Minimum accident	Contractor/Mabibo Ward/DAW ASA/Ubungo Municipal Council	5,000,000.00
<b>Demobilization Phase</b>									
Dust	Dust suppression -Use of efficient equipment	Presence of nuisance dust PM2.5 PM10	Weekly	Immediate working area	Presence of nuisance dust	Physical -visual	25 µg/m <sup>3</sup> for PM2.5 and 50 µg/m <sup>3</sup> for PM10	Contractor/Mabibo ward	1,000,000
Air Quality	use of personal protective equipment (PPE)	Smell and Odor	Weekly	Around the Inspection chambers	Presence of smells	Smelling (nasal)	Absence of nuisance smells	Mabibo Ward/DAW ASA/Ubungo Municipal Council	2,500,000.00
Waste Generation	-Provision storage containers	Amount of waste generated	Weekly	At the working area	Kg, tones and Cubic Meters for liquid waste	Physical measurement or estimation	All waste contained	Contractor/Mabibo Ward/DAW ASA/Ubungo Municipal Council	1,000,000
Health risks	-Provision of PPEs	Number of health risk recorded	Daily	At working area	Accidents/injuries	Counting and records	NO/Minimum accident	Contractor/Mabibo Ward/DAW ASA/Ubungo Municipal Council	5,000,000.00

**Comprehensive Project Brief of the Proposed construction of Simplified sewerage system at Mabibo jitegemee area**

---

<b>Environmental impact</b>	<b>Mitigation Measure</b>	<b>Parameter</b>	<b>Monitoring Frequency</b>	<b>Sampling Area</b>	<b>Measurement Unit</b>	<b>Method</b>	<b>Target Level/Standard</b>	<b>Responsibility for monitoring</b>	<b>Estimated Annual (or once cost (TZS)</b>
								o Municipal Council I	
								<b>TOTAL</b>	<b>29,500,000</b>

## **11.0 DECOMMISSIONING PLAN**

### **11.1 Decommissioning**

The decommissioning is not anticipated in the foreseeable future. However, if this will happen, may entail change of use (functional changes) or demolition triggered by change of land use. In view of this, specific mitigation measures pertaining to environmental impacts of decommissioning works cannot be proposed at the moment with a reasonable degree of certainty.

A decommissioning plan that takes environmental issues into consideration shall be prepared by the developer prior to the decommissioning works. Currently the study is discussing the preliminary plan that will be used as insight for Decommissioning plan in future.

This plan will serve to ensure that the decommissioning and ultimate dispositions of the residential buildings are considered during the initial design and construction of that facility.

### **11.2 Aim of the Preliminary Plan**

The preliminary plan serves to establish decommissioning as an important consideration from the inception of the project, during design and throughout the operation of the project. The plan has the following purposes:

- a) To ensure that the Sewer network project designers are aware of decommissioning during the initial design stage of the project.
- b) To identify the ultimate decommissioning options and final project status. Appropriate options would be evaluated and narrowed to the decommissioning method of choice as the end of project life is approached.
- c) To notify the regulatory agencies that, important aspects of decommissioning are considered as early as possible during the initial design of the project.

### 11.3 Content of the Preliminary Plan

The preliminary plan provides general description of the proposed decommissioning methods considered feasible for the project though with low level of significance. The description is intended to demonstrate that the methods considered are practical and that they protect the health and safety of the public and decommissioning personnel.

Design personnel should study the proposed decommissioning methods and ensure that the design incorporates all features that will facilitate decommissioning like;

- i). An estimate of manpower, materials and cost anticipated to support decommissioning processes.
- ii). A description of the anticipated final disposition and status of the structures at site as well as reinstatement of the project area.
- iii). Identification of records that should be maintained during construction and operation which might facilitate decommissioning.

### 11.4 Project Decommissioning Methodology and Schedule

The proponent shall implement all aspects of project decommissioning, including but not limited to, all engineering works, environmental assessment, permitting, construction, and mitigation activities associated with the removal of the structures. The proponent shall monitor environmental impacts during and after project removal to respond to defined events during the monitoring phase, some of the considerable issues to be addressed by the plan are:

1. Decommissioning will involve, but not limited to the specified list, because some issues or problems may raise during subsequent monitoring and audits;
  - Wherever possible, the pipelines, toilets and Manholes will continuously be rehabilitated and renovated. The solid wastes have to be disposed in accordance to the instruction directives given in EMSP and Ubungo Municipal Council Office that is decommissioning permit.

- Employees will be terminated from their employments. In doing this, three important things will be observed;
  - i. The proponent have to ensure that their contributions to the pension fund will be made monthly as required by the law
  - ii. A training programme will be facilitated to ensure that appropriate skills to responsible workers is adequately given.
  - iii. Terminations benefits such as transport and disturbance allowances will be provided to all employees.
- 2. On decommissioning the proponent will search for experts' opinions in order to convert the entire premises into or other uses.
- 3. The restoration plan for the entire premises will be made by proponent (with expertise from environmental engineers and economists) and then forwarded to NEMC for approval
- 4. DAWASA shall obtain all permits required to undertake decommissioning of the project.

The demotion process will begin soon after closure plan has completed and approved by the responsible organs. The proponent will make inventory to all components that need to be displaced, removed and or disposed. This inventory will include like building structures, equipment, and sanitary facilities that need to be demolished/dismantled. Lastly, mode of disposal will have to be finalized. The information will assist in the preparation of the final decommissioning plan for approval by NEMC.

After the approval of the decommissioning plan the metal parts will be removed first within the first three (3) months (it's important to ensure that they are not vandalized). The second three (3) months of the decommissioning will be used to remove concrete structures and foundations. All disturbed areas will be landscaped and re-vegetated using indigenous trees.

Project decommissioning has five phases;

---

1. Pre-removal monitoring: Pre-removal monitoring includes environmental and socio-economic status of the project site and the surrounding. This monitoring is essential to identify if there is any environmental or social liability which need to be settled before the permit to closure is given. This period will also be used to inventories all assets and facilities that need to be disposed of and to prepare a final decommissioning plan for approval by NEMC
2. Permitting: DAWASA shall obtain all permits required to undertake removal of the project structures. This basically will include NEMC, Ubungo Municipal Council and other stakeholders that will be recommended at that particular time.
3. Interim Protective Actions: This will take care of any interim protective measure that needs to be implemented to protect human health and environment, if any.
4. Project Removal: As noted above, the removal of the project will be completed within one year.

Post-Removal Activities: Post-Project removal monitoring will continue for one year







## **12.0 PROJECT BUDGET**

The investment cost for the proposed Simplified sewerage system is estimated to be around Tshs. 1.0 billion that will be financed The World Bank.

Appendix I: List of Stakeholders Consulted







**ENVIRONMENTAL AND SOCIAL IMPACT ASSESSMENT FOR CONSTRUCTION OF OFF GRID SANITATION PROJECTS,  
DAR ES SALAAM**

**LIST OF STAKEHOLDERS CONSULTED**

SN	DATE/TAREHE	NAME/JINA	INSTITUTION/TAASISI	POSITION/CHEO	PHONE NO./SIMU	SIGNATURE/SAINI
1	21/7/2020	MATHIAS LUZOREKA	UME	Ag ME	0714-662078	
2	21/07/2020	Nice Vahuye	UMC	Ag MESO	0713 945432	
3	21/07/2020	LEAH SIWAU	UMC	mtumwa	0713 4255 25	
4	21/7/2020	Non A. liyau	UMC	Architect	0714419709	
5	21/7/2020	ROBERT AMARI	MAYUMBA	HEAD TEACHER	0654996198	
6	23/07/2020	CHANDA G. MAMBARA	WESARANGA	WE	0713396995	

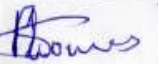
ENVIRONMENTAL AND SOCIAL IMPACT ASSESSMENT FOR CONSTRUCTION OF OFF GRID SANITATION PROJECTS,  
DAR ES SALAAM

LIST OF STAKEHOLDERS CONSULTED

SN	DATE/TAREHE	NAME/JINA	INSTITUTION/TAASISI	POSITION/CHEO	PHONE NO./SIMU	SIGNATURE/SAINI
	23/07/2020	JAHARI MAYANGA	MIA-MATANINI	MTENDAJI	0715-395350	
	23.07.2020	MASUDI M. MKWANGA	S/MSINGI MSEWE	M/MKUU	0754-991385	
	23-07-2020	BERNARD T. MKUWE	S/MSINGI MSEWE	MTENDAJI	4713 966970	
	23/07/2020	BLAMWA R. SWOT	S/M. UKOMBOZI	M/MKUU	0716 668870	
	23/07/2020	DIANA JUMA	AFISA AFYA KATA-MANZEE	A/AFYA	0692 549549	
	23.07.2020	MASHAHI ZUBEIR	AFISA AFYA KATA-MANZEE	AI-KATA	0743-557283	

Appendix II: Permit to use the walkways/alleys for SSS infrastructures

**HALMASHAURI YA MANISPAA YA UBUNGO**

OF-ISI YA SERIKALI YA  
MTAA, MTAA WA  
JITEGEMEE, KATA YA  
MABIBO.  
S.L.P 55068,  
DAR ES SALAAM,  
12/07/2021.

KWA,  
AFISA MTENDAJI MKUU WA DAWASA

ENZI

YAH: IDHINI YA KUTUMIA MAENEO PENDEKEZWA KWA AJILI YA UJENZI  
WA MIRADI YA USAFI WA MAZINGIRA.

kali ya  
isafi wa  
P II).

Tafadhali husika na mada tajwa hapo juu.

Tafadhali rejea mawasiliano yako ya awali kati ya Dawasa na Ofisi ya Jitegemee kuhusu utoaji wa maeneo ya wazi kwa ajili ya ujenzi wa miradi Mazingira maeneo pembezoni iliyo chini ya ufadhili wa Benki ya Dunia

Serikali  
ya usafi  
(WSSP

Kwa barua hii tunakujulisha kuwa Serikali ya Mtaa kupitia kikao chake cha tarehe 12/07/2021 imetoa idhini ya kutumia maeneo yaliyopendekezwa kwa ajili ya ujenzi wa miradi ya ukusanyaji na uondoshaji maji taka (Simplified Sewerage System) maeneo yatakayotumika kwa ajili ya mradi ni njia rasmi na zisizo rasmi hapa mtaani.



0713 514 988

Appendix III. Minutes of Meetings Conducted

TATHIIMUNI YA BTHARI KWA NAZILOGIRA NA JAMU NA  
UHAWAISHAJI KWA JAMU KUTUSU MPANGO WA MAKAZI  
MABADALA NA FIDIA ZIKUKANAZO NA MRADI WA UJENZI  
WA MUNDOMBINU YA UCHAKATAJI MASI TAKA NA VICO  
VYA UMMA MUDA WA DAR-E-SALAM  
(MTAA WA JITEGEMEE) 22/07/2020

AGENDA

1. KUFUNGUWA KIKAO
2. MAELEZO KUTUSU MRADI
3. MASWALI / MABONI KUTOKA KWA WADAI
4. KUATHIRISHA KIKAO

1. KUFUNGUWA KIKAO  
Kikao kilitengulwa na mwenyekiti ndugu  
Yusufu Killema mnamo muda wa saa 6.20  
mchana na kisha kuwatambulisha wataala-  
mu kutoka kampuni ya Royal Associate  
Engineering JV. G-PES LTD Kiambatana na mwekazi  
wake DAWASA.  
Baada ya utambulisho mwenyekiti aliwakambisha  
wataalamu kutoka maelezo ya mradi.

2. MAELEZO KUTUSU MRADI WA MABOMBA YA MASI TAKA  
Mtaalamu Mshauri kutoka kampuni ya Royal  
Associate Engineering JV G-PES LTD, alisimama  
na kueleza kuwa wamekuja kutoka taarifa juu  
ya ujemi wa mabomba ya maji laka ambayo



Yataunganishwa na kupelekea kwenye mabwawa vyo vyote vya mtaa wa jitegemee vitaunganishwa na mabomba ili maji taka yaeleke kwenye mabwawa. Kama chuo chako ni cha shimo DAWARA itawajengea chuo na utakuwa mnalipia kidogo kidogo kwa mda wa miaka miwili na bei ya chuo kipyaa Inaamria kwenye laki sita. Na malipo ya chuo kutengeneza haina lipa. Na malipo ya hii huduma ni kwa mwezi.

~~MABWAWA / MAONI KUTOKA KWA WARAAU~~

James Mwakeja - Amekubaliana na huu mradi wa kuunganishwa mabomba ya maji taka.

Utaalamu ndugu Adam kutoka DARAWA aliongeza mfumo huu ni mabomba yanakuya moja kwa moja kwenye nyumba yako na kupeleka maji taka moja kwa moja mpaka kwenye Mabwawa. Aliendelea na kusema huu mfumo unahitaji sana maji ili yale maji taka lile tope liweze kupita, hivyo pampers na taka ngumu zisiwekwe ama kutupwa kwenye haya mabomba.

Kevin Kamora - Aliuliza watakaathinika na huu mradi utakuwaje?

Utaalamu ndugu Adam alijibu haya maeneo ni ya kipelekerwa na Manispaa na mabomba ni madogo sana ambayo hayataathini mte hivyo kama mtu hatotaka kuunganishwa ni sawa kwani unafanya kwa hiari ya mte.

Utendaji  
Alienye kuti aliomba huu mradi utetue mapema



Kevin Kamora- aliuliza kama mabomba yame-  
haribika au yameriba utakuwaje?

Mtaalamu kutoka DAWASA ndugu Adam alisema  
huwa tunaunda vikundi na Mwenyekiti wa  
hiko kikundi hutoa taarifa DAWASA ikiwa  
kuna bomba limeparuka ili tuwe na rishikishi  
kati ya DAWASA na wanandui.

Kevin Kamora- Aliuliza je gharama zikipanda  
utakuwaje?

Mtaalamu alijibu gharama za huduma hwa  
zinapangwa na EWURA.

John Felisiani- Aliuliza je utekeleraji wa huu  
mradi upoje.

Mtaalamu alijibu taarifa zote za utekeleraji  
utapata kutoka kwa mtendaji na mradi  
unategemea kuanza mwezi wa tisa.

4. KUHAHURISHA KIKAO

kikao kilialihishwa na Mwenyekiti kuanza  
Muda wa saa 7:00 mchana.

Sahibi ya Mwenyekiti



YUSUPH  
0712

Sahibi ya



Mzee. M. Mwanjama  
0713514988



TATHIMINI YA ATHARI KWA MAZINGIRA NA JAMII NA UHAMASISHAJI KWA JAMII KUHUSU MPANGO WA MAKAZI MBADALA NA FIDIA ZITOKANAZO NA MIRADI WA UENZI WA MIUNDOMBINU YA UCHAKATAJI MAJI TAKA NA VYOO VYA UMMA MKOA WA

DAR ES SALAAM

MAHUDHURIO KWA AJILI YA MIKUTANO, MAJADILIANO

MWEKEZAJI: DAWASA  
 WILAYA: UBUUNGU  
 KATA: MABIBO  
 MSHAURI: ROYAL ASSOCIATES ENGINEERING JV G-PES LTD  
 MTAA: JITEGEMEJE  
 TAREHE: 22/07/2020

S/N	JINA	WADHIFA	NAMBA YA SIMU	SAHIHI
1.	YUSUF KI KWAHA	MUKITI	0712660594	Del
2.	JACOB A. KWAHAHA	KABU CCm 2ndi	0684-900730	Del
3.	KEDIMUNI E-SEMWALI	KIMWENEGEM JAMU	0656 516772	K. Semwaly
4.	Juma Hussein Hamis	Mwawanchi	0777 522 503	J.H Hamis
5.	KELVIN A KAMU	MWANANACHA	0652-180804	del
6.	MIPINDUZ MIBULI	MWANANACHA	0757915559	del
7.	BESTO KIKOII	MWANANACHA	0715 5009	del
8.	JOHN FELICIAN LIPINGU	MWANANACHA	0783-201900	del
9.	MOHAMED AMFILI	MWANANACHA	0715 46991	del
10.	RAJAB KHAFIJI	Mwananchi	0715-884722	del
11.	HIDA GEORGE SUSSEH	MST	0655-555447	del
12.	HAWA JUMA	MWANANACHA	0787-392519	H. Juma
13.	ALI HALUWA	MWANANACHA	0717 031110	del
14.	ASHTAR RASHID	MWANANACHA	0689-219296	del
15.	MADOLIMU MAAKIFA	Mwananchi	0655-423250	del
16.	DETD. MAAKIFA	Mwananchi	0719-532775	del
17.	PAMODHANI SPICINE ITZI	Mwananchi	0713-393337	del
18.	ALY T. PAPA	MWANANACHA	0715 521118	del
19.	PHILIPUS (A) MUSA (HAKIKI)	Mwananchi	0710-28727399	del
20.	HOSSENI H. KIMINDU	MWANANACHA	0655-844855	del
21.	MACE. M. MWAHA	MWANANACHA	0713 514988	del

Appendix IV. Architectural Drawings

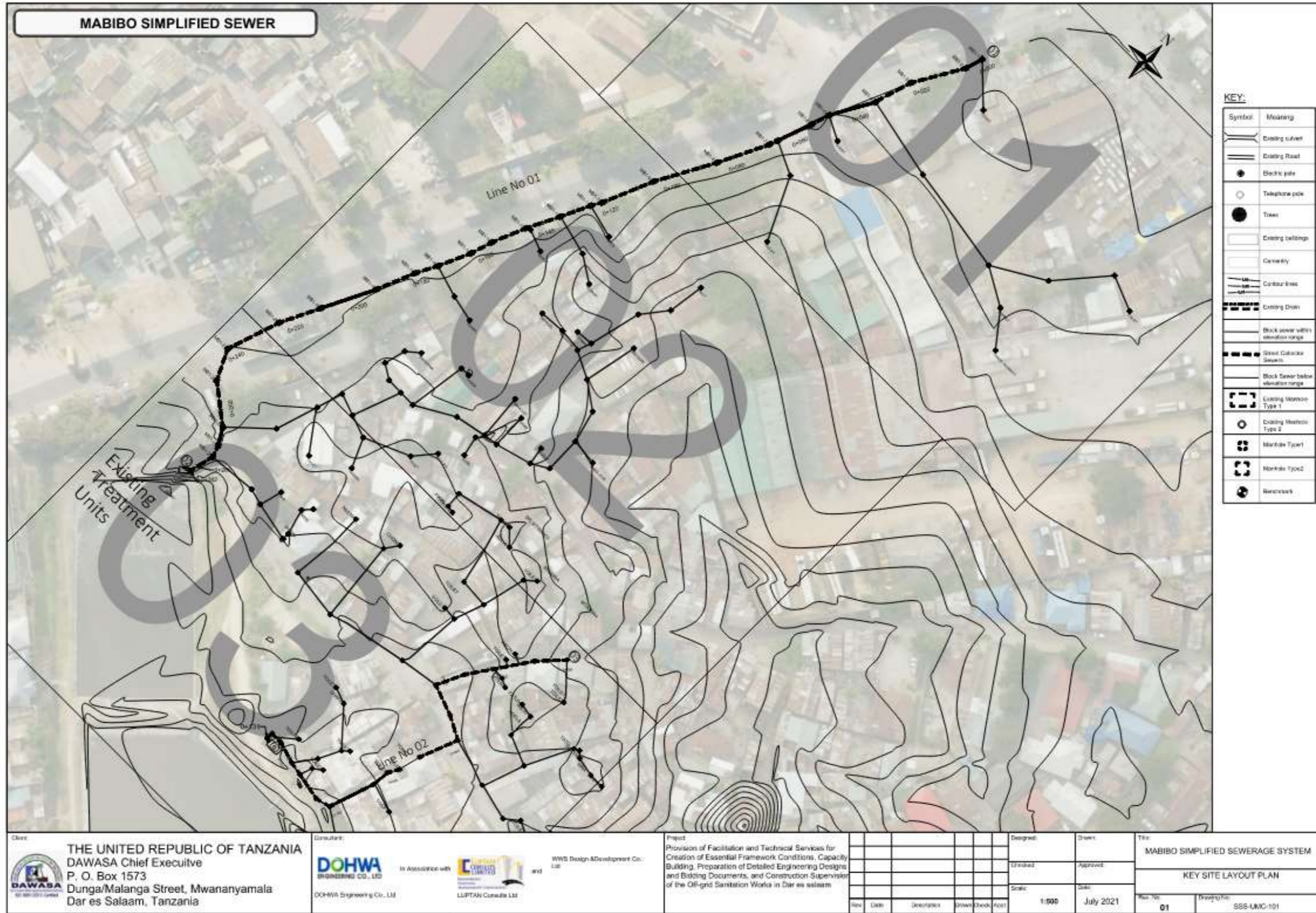

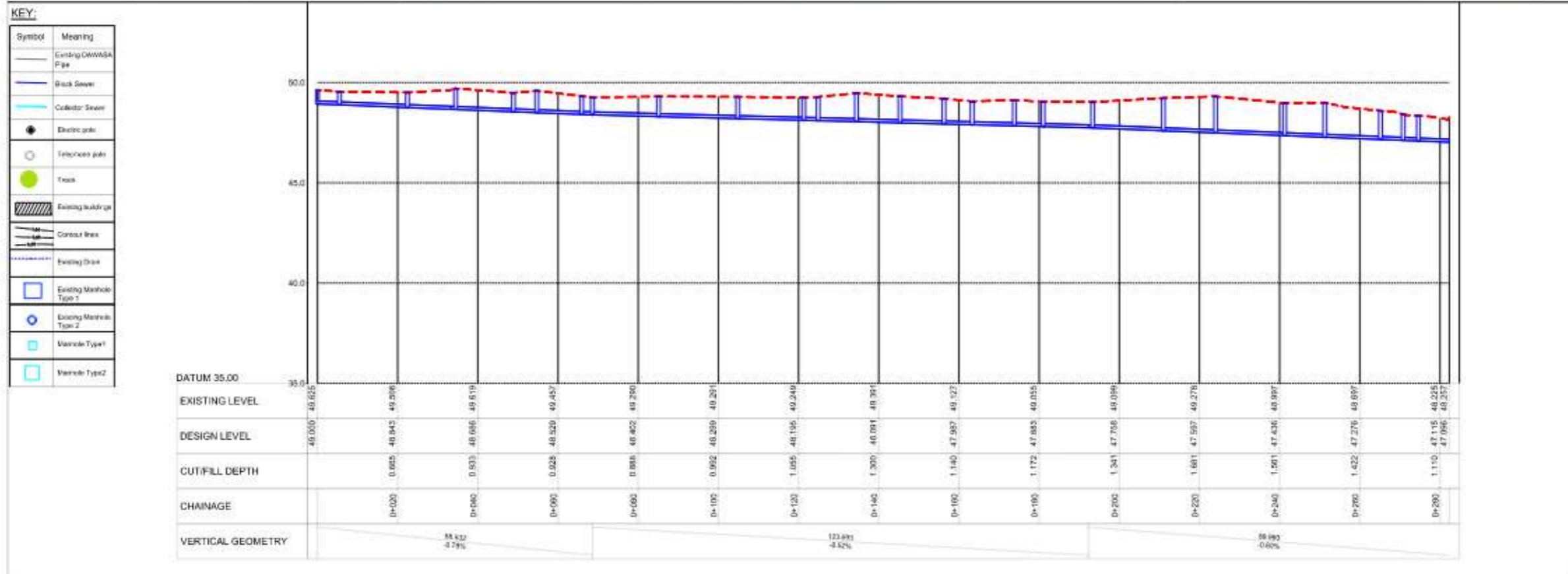
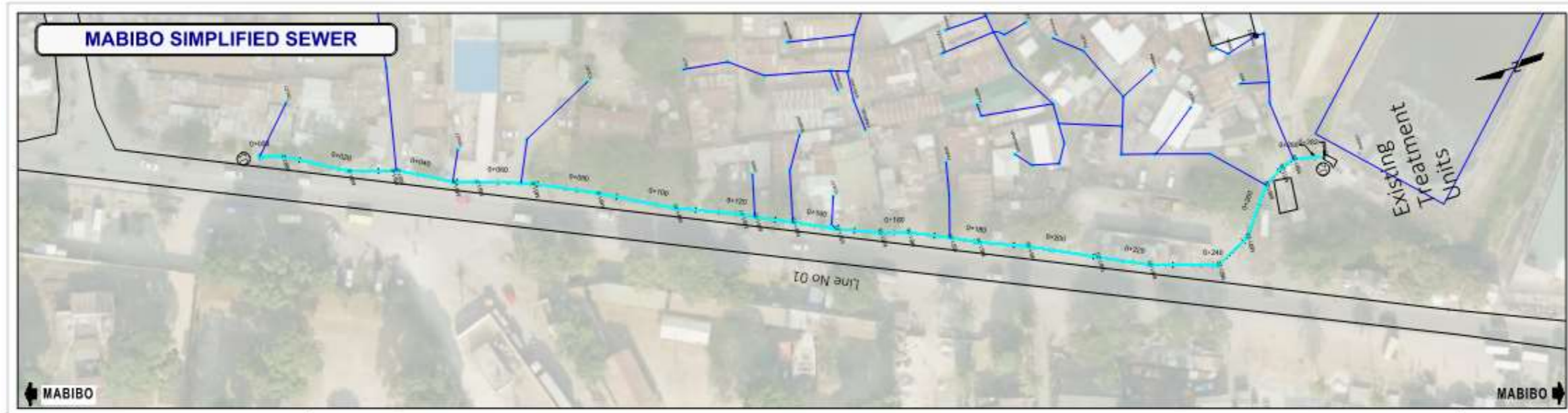

<p><b>THE UNITED REPUBLIC OF TANZANIA</b> DAWASA Chief Executive P. O. Box 1573 Dunga/Malanga Street, Mwananyamala Dar es Salaam, Tanzania</p>	<p><b>DOHWA</b> Engineering Co., Ltd. In Association with LUPTAN CONSULTANTS LUPTAN CONSULTANTS Ltd.</p>	<p>WSD Design &amp; Development Co. Ltd.</p>	<p>Project: Provision of Facilitation and Technical Services for Creation of Essential Framework Conditions, Capacity Building, Preparation of Detailed Engineering Designs and Bidding Documents, and Construction Supervision of the Off-grid Sanitation Works in Dar es Salaam</p>	Designed	Drawn	<p>Title: <b>MABIBO SIMPLIFIED SEWERAGE SYSTEM</b></p>
				Checked	Approved	
<p>PLAN AND PROFILE FOR LINE NO 01</p> <p>D+004.00 to D+282.32</p>				<p>Sheet No: <b>01</b></p>		<p>Drawing No: <b>BSS-UMC-PP-201</b></p>

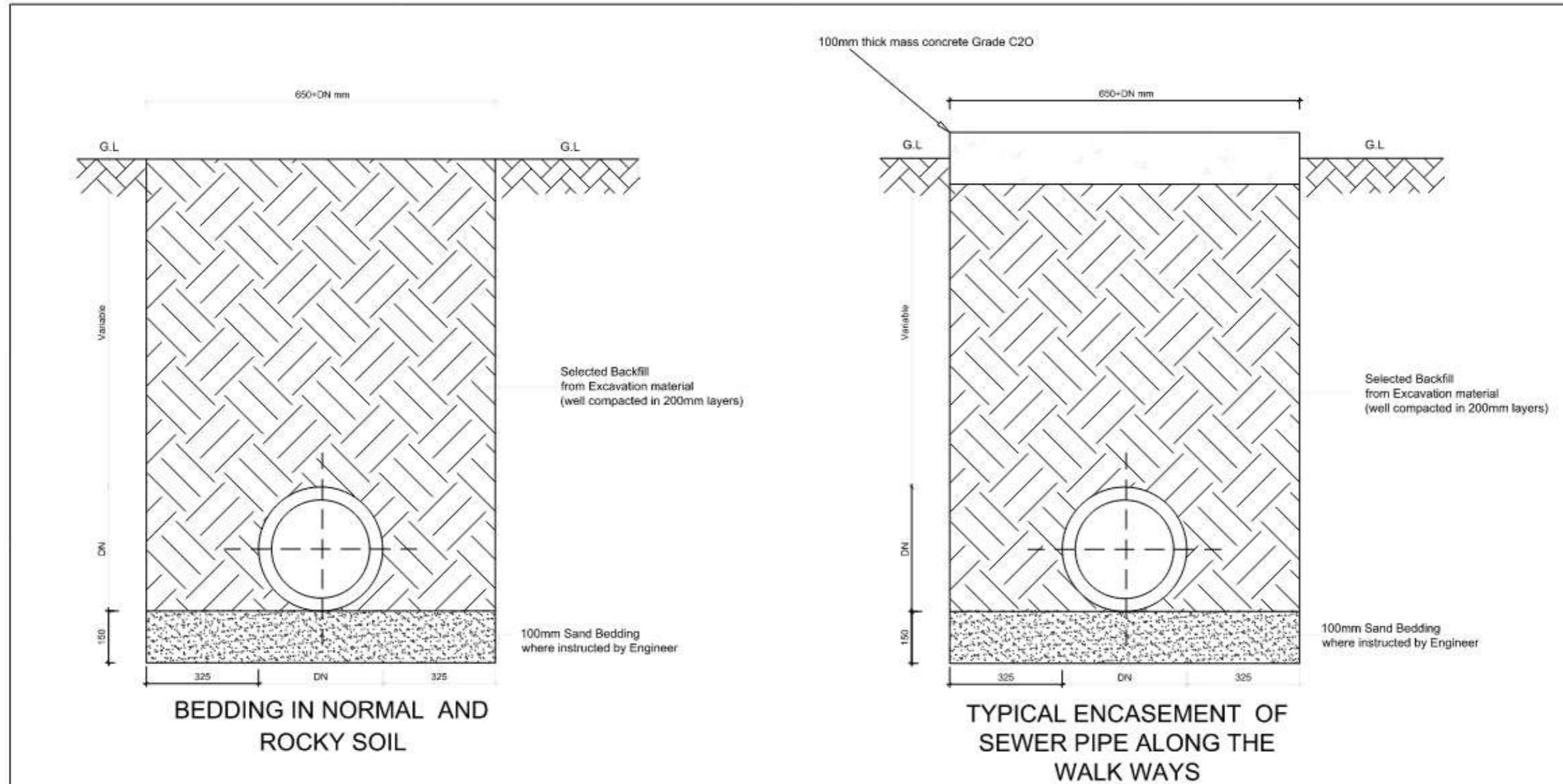

- Notes:**
1. Minimum width of trench excavation is 750mm and Maximum width is 850mm. In the areas where available width is less than the required width to excavate, the contractor will inform the engineer for approval.
  2. Minimum depth for excavation for collector sewers is 0.8m and for block sewer is 0.4m. Excavation depths will vary depending on the slope requirement and existing ground level as per drawing.
  3. The contractor will be required to confirm all levels to maintain slope of pipeline as indicated in the hydraulic setting out data

<p>THE UNITED REPUBLIC OF TANZANIA DAWASA Chief Executive P. O. Box 1573 Dunga/Malanga Street, Mwananyamala Dar es Salaam, Tanzania</p>	<p>DOHWA ENGINEERING CO., LTD In Association with LUPITAN CONSULTANTS LTD WAS Design &amp; Development Co. Ltd</p>	<p>Project: Provision of Facilitation and Technical Services for Creation of Essential Framework Conditions, Capacity Building, Preparation of Detailed Engineering Designs and Bidding Documents, and Construction Supervision of the Off-grid Sanitation Works in Dar es Salaam</p>	Designed: _____ Checked: _____ Scale: NTS	Drawn: _____ Approved: _____ Date: July, 2021	Title: SIMPLIFIED SEWER SYSTEM STANDARD DETAILS DRAWINGS TYPICAL CROSS SECTIONS AND TRENCH DETAILS
			Rev: _____ Date: _____ Description: _____ Drawn: _____ Check: _____ Appr: _____	No. Rev: 01 Drawing No: SSS-STD-301	

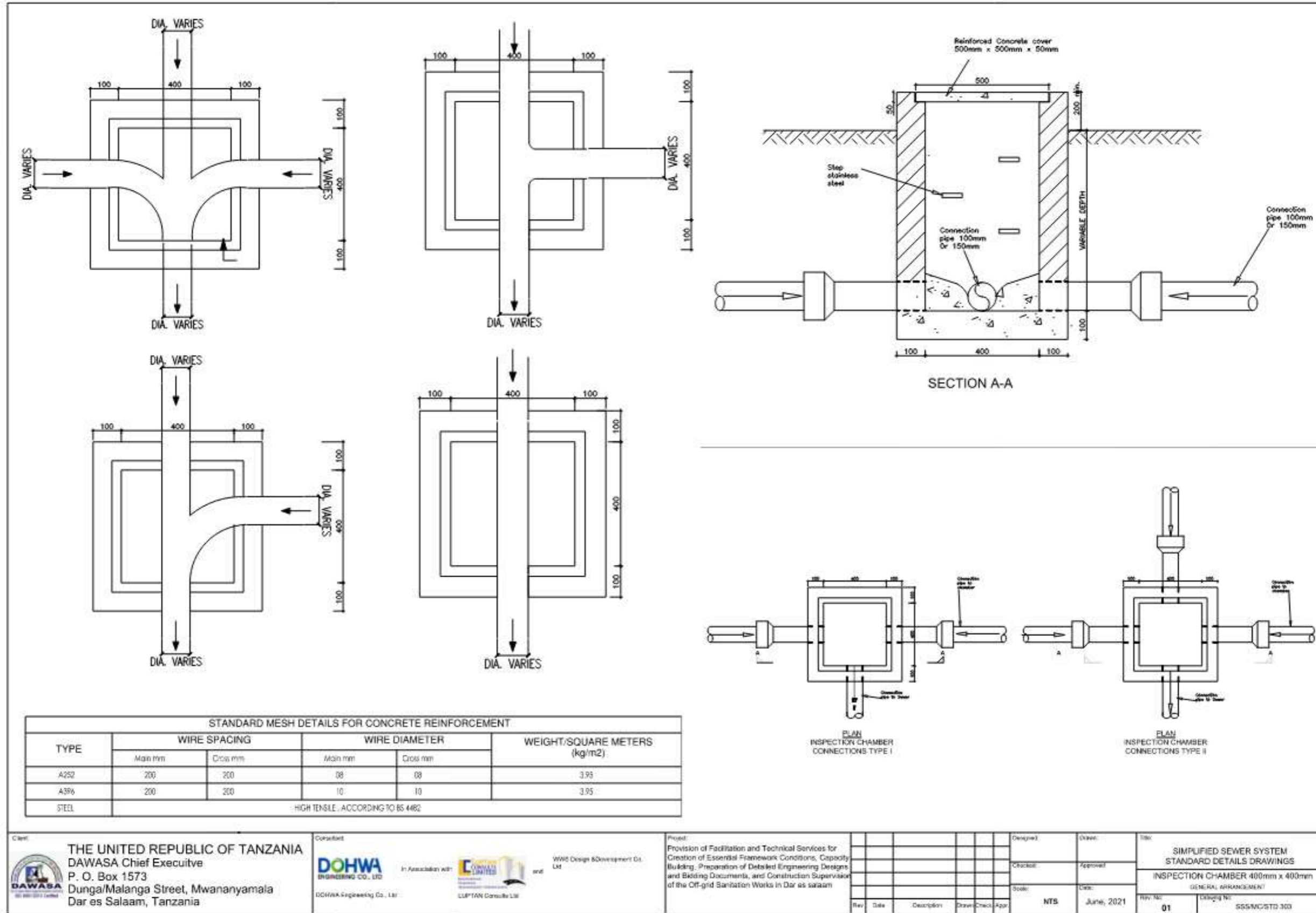

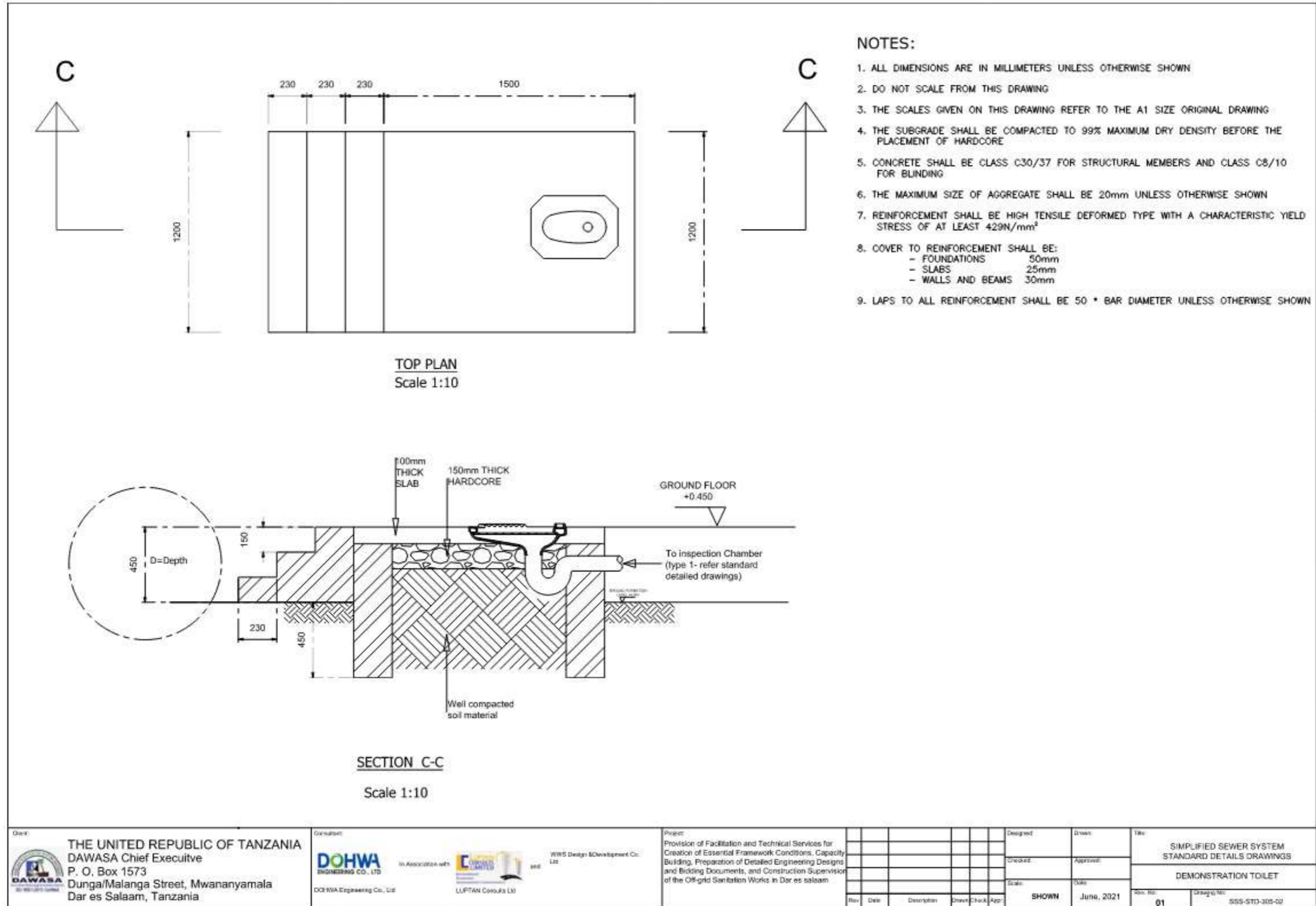

## Annex I: Generic Environmental Management for Construction Activities

### ENVIRONMENTAL MANAGEMENT OF CONSTRUCTION ACTIVITIES

Proper environmental management of construction projects can be achieved only with adequate site selection and project design. As such, the Environmental and Social Assessment (ESA) for subprojects involving any new construction, or any rehabilitation or reconstruction for existing projects, should provide information as to screening criteria for site selection and design including the following:

#### 1.1 SITE SELECTION

Sites should be chosen based on community needs for additional projects, with specific lots chosen based on geographic and topographic characteristics. The site selection process involves site visits and studies to analyze: (i) the site's urban, suburban, or rural characteristics; (ii) national, state, or municipal regulations affecting the proposed lot; (iii) accessibility and distance from inhabited areas; (iv) land ownership, including verification of the absence of squatters and/or other potential legal problems with the land acquisition; (v) determination of site vulnerability to natural hazards, (i.e. intensity and frequency of floods, earthquakes, landslides, hurricanes, volcanic eruptions); (vi) suitability of soils and subsoils for construction; (vii) site contamination by lead or other pollutants; (viii) flora and fauna characteristics; (ix) presence or absence of natural habitats and/or ecologically important habitats on-site or in the vicinity (e.g. forests, wetlands, coral reefs, rare or endangered species); and (ix) historic and community characteristics.

#### 1.2 PROJECT DESIGN

Project design criteria include, but are not limited to, the consideration of aspects such as heating, ventilation, natural and artificial light energy efficiency, floor space (ft<sup>2</sup>) per bed/ward, requirements for x-ray rooms, adequacy of corridors for wheelchair/bed access, adequate water supply and sanitation systems, historical and cultural considerations, security and handicapped access.

#### 1.3 CONSTRUCTION ACTIVITIES AND ENVIRONMENTAL RULES FOR CONTRACTORS

The following information is intended solely as broad guidance to be used in conjunction with local and national regulations. Based on this

information, environmental rules for contractors should be developed for each project, taking into account the project size, site characteristics, and location (rural vs. urban).

After choosing an appropriate site and design, construction activities can proceed. As these construction activities could cause significant impacts on and nuisances to surrounding areas, careful planning of construction activities is critical. Therefore the following rules (including specific prohibitions and construction management measures) should be incorporated into all relevant bidding documents, contracts, and work orders.

### 1.3.1 Prohibitions

The following activities are prohibited on or near the project site:

- Cutting of trees for any reason outside the approved construction area;
- Hunting, fishing, wildlife capture, or plant collection;
- Use of unapproved toxic materials, including lead-based paints, asbestos, etc.
- Disturbance to anything with architectural or historical value;
- Building of fires;
- Use of firearms (except authorized security guards);
- Use of alcohol by workers.

### 1.3.2 Construction Management Measures

Waste Management and Erosion:

Solid, sanitation, and, hazardous wastes must be properly controlled, through the implementation of the following measures:

Waste Management:

- Minimize the production of waste that must be treated or eliminated.
- Identify and classify the type of waste generated. If hazardous wastes (including health care wastes) are generated, proper procedures must be taken regarding their storage, collection, transportation, and disposal.
- Identify and demarcate disposal areas indicating the specific materials that can be deposited in each.
- Control placement of all construction waste (including earth cuts) to approved disposal sites (>300 m from rivers, streams, lakes, or wetlands). Disposal of in authorized

areas all of garbage, metals, used oils, and excess material generated during construction, incorporating recycling systems and the separation of materials.

**Maintenance:**

- Identify and demarcate equipment maintenance areas (>15m from rivers, streams, lakes, or wetlands).
- Ensure that all equipment maintenance activities, including oil changes, are conducted within demarcated maintenance areas; never dispose of spent oils on the ground, in watercourses, drainage canals, or in sewer systems.
- Identify, demarcate and enforce the use of within-site access routes to limit the impact to site vegetation.
- Install and maintain an adequate drainage system to prevent erosion on the site during and after construction.

**Erosion Control**

- Erect erosion control barriers around the perimeter of cuts, disposal pits, and roadways.
- Spray water on dirt roads, cuts, fill material and stockpiled soil to reduce wind-induced erosion, as needed.
- Maintain vehicle speeds at or below 10mph within the work area at all times.

**Stockpiles and Borrow Pits**

- Identify and demarcate locations for stockpiles and borrow pits, ensuring that they are 15 meters away from critical areas such as steep slopes, erosion-prone soils, and areas that drain directly into sensitive water bodies.
- Limit extraction of material to approved and demarcated borrow pits.

**Site Cleanup**

- Establish and enforce daily site clean-up procedures, including maintenance of adequate disposal facilities for construction debris.

**1.3.3 Safety During Construction**

The Contractor's responsibilities include the protection of every person and nearby property from construction accidents. The Contractor shall be responsible for complying with all national and local safety

requirements and any other measures necessary to avoid accidents, including the following:

- Carefully and mark pedestrian-safe access routes. ○ If school children are in the vicinity, include traffic safety personnel to direct traffic during school hours.
- Maintain a supply of supplies for traffic signs (including paint, easel, sign material, etc.), road marking, and guard rails to maintain pedestrian safety during construction.
- Conduct safety training for construction workers before beginning work.
- Provide personal protective equipment and clothing (goggles, gloves, respirators, dust masks, hard hats, steel-toed and –shanked boots, etc.) for construction workers and enforce their use.
- Post Material Safety Data Sheets for each chemical present on the worksite.
- Require that all workers read, or are read, all Material Safety Data Sheets. Clearly explain the risks to them and their partners, especially when pregnant or planning to start a family. Encourage workers to share the information with their physicians, when relevant.
- Ensure that the removal of asbestos-containing materials or other toxic substances is performed and disposed of by specially trained workers.
- During heavy rains or emergencies of any kind, suspend all work.
- Brace electrical and mechanical equipment to withstand seismic events during the construction.

#### **1.3.4 Nuisance and dust control**

To control nuisance and dust the Contractor should:

- Maintain all construction-related traffic at or below 15 mph on streets within 200 m of the site.
- Maintain all on-site vehicle speeds at or below 10 mph.
- To the extent possible, maintain noise levels associated with all machinery and equipment at or below 90 dB.
- In sensitive areas (including residential neighborhoods, hospitals, rest homes, etc.) more strict measures may need to be implemented to prevent undesirable noise levels.
- Minimize production of dust and particulate materials at all times, to avoid impacts on surrounding families and businesses, and especially to vulnerable people (children, elders).

- Phase removal of vegetation to prevent large areas from becoming exposed to wind.
- Place dust screens around construction areas, paying particular attention to areas close to housing, commercial areas, and recreational areas.
- Spray water as needed on dirt roads, cut areas, and soil stockpiles or fill material.
- Apply proper measures to minimize disruptions from vibration or noise coming from construction activities.

### 1.3.5 Community Relations

To enhance adequate community relations the Contractor should:

- Following the country and EA requirements, inform the population about construction and work schedules, interruption of services, traffic detour routes, and provisional bus routes, as appropriate.
- Limit construction activities at night. When necessary ensure that night work is carefully scheduled and the community is properly informed so they can take necessary measures.
- At least five days in advance of any service interruption (including water, electricity, telephone, bus routes) the community must be advised through postings at the project site, at bus stops, and in affected homes/businesses.

### 3.1.6 Chance Find Procedures for Culturally Significant Artifacts

The Contractor is responsible for familiarizing themselves with the following “Chance Finds Procedures”, in case culturally valuable materials are uncovered during excavation, including:

- Stop work immediately following the discovery of any materials with possible archeological, historical, paleontological, or other cultural value, announce findings to project manager, and notify relevant authorities;
- Protect artifacts as well as possible using plastic covers, and implement measures to stabilize the area, if necessary, to properly protect artifacts
- Prevent and penalize any unauthorized access to the artifacts o Restart construction works only upon the authorization of the relevant authorities.

1.4	ENVIRONMENTAL SUPERVISION DURING CONSTRUCTION
<p>The bidding documents should indicate how compliance with environmental rules and design specifications would be supervised, along with the penalties for non-compliance by contractors or workers. Construction supervision requires oversight of compliance with the manual and environmental specifications by the contractor or his designated environmental supervisor. Contractors are also required to comply with national and municipal regulations governing the environment, public health, and safety.</p>	